

Chapter Fifty-eight
SPECIAL DESIGN ELEMENTS

BUREAU OF DESIGN AND ENVIRONMENT MANUAL

Chapter Fifty-eight
SPECIAL DESIGN ELEMENTS

Table of Contents

<u>Section</u>	<u>Page</u>
58-1 ACCESSIBILITY STANDARDS FOR THE DISABLED	58-1.1
58-1.01 General	58-1.1
58-1.01(a) Referenced Accessibility Standards	58-1.1
58-1.01(b) Scoping Requirements - New Construction, Added Elements, and Alterations	58-1.1
58-1.01(c) Maintaining Accessibility During Construction	58-1.2
58-1.02 Buildings and Facility Sites	58-1.3
58-1.03 Bus Stops	58-1.3
58-1.04 Parking	58-1.4
58-1.04(a) Off-Street Parking	58-1.4
58-1.04(b) On-Street Parking	58-1.4
58-1.05 Accessible Route	58-1.7
58-1.05(a) Definition	58-1.7
58-1.05(b) Selecting Accessible Routes	58-1.7
58-1.06 Sidewalks	58-1.7
58-1.07 Stairs	58-1.9
58-1.08 Ramps	58-1.10
58-1.09 Curb Ramps	58-1.11
58-1.09(a) Responsibility for Construction of Curb Ramps	58-1.12
58-1.09(b) Design and Construction of Curb Ramps	58-1.12
58-1.09(c) Detectable Warning Surfaces	58-1.14
58-1.09(d) Crossing Controls	58-1.14
58-1.10 Pedestrian Overpasses and Underpasses	58-1.15
58-1.11 Rest Areas	58-1.15
58-2 OFF-STREET PARKING	58-2.1
58-2.01 Park-and-Ride Lots	58-2.1
58-2.01(a) Location	58-2.1
58-2.01(b) Layout	58-2.2
58-2.02 Replacement Parking Guidelines	58-2.3
58-2.03 Design Elements	58-2.4

58-3 BUS STOPS AND TURNOUTS58-3.1

58-3.01 Location58-3.1

58-3.01(a) Bus Stops..... 58-3.1

58-3.01(b) Bus Turnouts..... 58-3.1

58-3.01(c) Selection 58-3.3

58-3.02 Design 58-3.3

58-3.02(a) Bus Stops..... 58-3.3

58-3.02(b) Bus Turnouts..... 58-3.3

58-3.02(c) Bus Stop Pads 58-3.6

58-3.02(d) Bus Shelters..... 58-3.6

58-4 FENCING 58-4.1

58-4.01 General..... 58-4.1

58-4.01(a) Location 58-4.1

58-4.01(b) Fence Types 58-4.1

58-4.02 Freeways (Fully Access Controlled) 58-4.2

58-4.03 Expressways (Partial Access Control)..... 58-4.3

58-4.04 Protective Fencing on Highway Overpasses 58-4.4

58-4.04(a) General 58-4.4

58-4.04(b) Evaluation of Need..... 58-4.4

58-4.04(c) Pedestrian Bridges..... 58-4.4

58-4.05 Fencing or Safety Devices on Top of Retaining Walls 58-4.4

58-5 MAILBOX TURNOUTS 58-5.1

58-5.01 Location 58-5.1

58-5.02 Design Features 58-5.5

58-5.02(a) Typical Designs..... 58-5.5

58-5.02(b) Special Designs 58-5.8

58-5.03 Mailbox Supports 58-5.9

58-6 RECREATIONAL ROADS 58-6.1

58-7 SEALING OF ABANDONED WATER WELLS 58-7.1

58-8 SURVEY MARKERS AND MONUMENTS 58-8.1

58-8.01 Right-of-way Markers 58-8.1

58-8.02 Permanent Survey Markers..... 58-8.1

58-8.03 Permanent Survey Ties 58-8.2

58-8.04 Land Survey Monuments..... 58-8.2

58-9 REFERENCES.....58-9.1

Chapter Fifty-eight

SPECIAL DESIGN ELEMENTS

58-1 ACCESSIBILITY STANDARDS FOR THE DISABLED

58-1.01 General

58-1.01(a) Referenced Accessibility Standards

Section 504 (49 CRF Part 27) of the Rehabilitation Act of 1973 (29 USC 794), the Illinois Environmental Barriers Act (410 ILCS 25/1), and Title II (28 CFR Part 35) of the Americans with Disabilities Act (ADA) of 1990 (42 USC 12131) prohibit discrimination on the basis of disability by public entities. To that end, the following sections present guidance which is intended to ensure the Department's newly constructed facilities, and existing facilities being altered, are accessible to the disabled. The guidance is generally based on information presented in the *2010 ADA Standards for Accessible Design* and the *Illinois Accessibility Code*. However, for situations in the public right of way that are not specifically or adequately addressed by either of the above standards, the guidance is taken from information presented in the *Draft Public Rights-of-Way Accessibility Guidelines (Draft PROWAG)*.

Where other agencies or local codes require criteria which exceed the above referenced standards, then the stricter criteria may be required. This will be determined on a case-by-case basis.

58-1.01(b) Scoping Requirements - New Construction, Added Elements, and Alterations

When determining the scope of an improvement, the following categories of action must be considered.

1. New Construction. Newly constructed facilities shall fully comply with the applicable accessibility requirements.
2. Added Elements. Elements added to existing facilities shall fully comply with the applicable accessibility requirements. However, where elements are added to existing facilities but the pedestrian circulation path serving the added elements is not altered, the pedestrian circulation path is not required to be altered if out of compliance. For example, if a new bench is installed on an existing sidewalk that has a cross slope exceeding 2 %, the sidewalk is not required to be altered to reduce the cross slope because the bench is installed on the sidewalk.
3. Alterations. Alterations are changes to an existing facility that affect or could affect pedestrian access, circulation, or use. Alterations include, but are not limited to, resurfacing, rehabilitation, reconstruction, historic restoration, or changes or rearrangement of structural parts or elements of a facility. Altered elements, spaces, or

facilities shall comply with the applicable accessibility requirements to the greatest extent practicable within the scope of the project. This typically means that alterations must be fully compliant; however, there are exceptions.

- Existing Physical Constraints. Where existing physical constraints make it impracticable for altered elements, spaces, or facilities to fully comply with the applicable accessibility requirements, compliance is required to the extent practicable within the scope of the project. Existing physical constraints include, but are not limited to, underlying terrain, right-of-way availability, underground structures, adjacent developed facilities, drainage, or the presence of a notable natural or historic feature.
- Alterations to Qualified Historic Facilities. Where the State Historic Preservation Officer or Advisory Council on Historic Preservation determines that compliance with a requirement would threaten or destroy historically significant features of a qualified historic facility, compliance shall be required to the extent that it does not threaten or destroy historically significant features of the facility.
- Transitional Segments. Transitional segments used to connect new, added, or altered elements to existing unaltered elements shall comply to the extent practicable.

One other requirement for alterations is they shall not decrease or have the effect of decreasing the accessibility of a facility or an accessible connection to an adjacent building or site.

The issue of whether resurfacing constitutes an alteration within the scope of Section 504 of the Americans with Disabilities Act (ADA) was at the heart of a court case in Philadelphia, PA (**Kinney v. Yerusalim**, 9 F.3d 1067 (3d Cir. 1993), cert. denied, 511 U.S.C. 1033 (1994)). The plaintiffs argued that the City of Philadelphia violated the ADA when the City only installed curb cuts when work on the City streets otherwise affected the curb or sidewalk and not during resurfacing projects. The City did not dispute the requirement that the regulations mandate the installation of curb cuts when the City “alters” a street. The City protested the notion that resurfacing of a street constituted an alteration. The judgment determined an alteration occurs when the usability of a facility is affected, and, if affected, the alteration should apply to all users. Further an interpretation of the guidelines determined interdependency between the street and its curbs. If a street is to be altered to make it more usable for the general public, it also must be made more usable for those with ambulatory disabilities thus requiring installation or upgrading of curb ramps.

58-1.01(c) Maintaining Accessibility During Construction

During construction, accessibility must be maintained consistent with the features present in the existing facility. If a project is being constructed in stages, the designer may need to provide for the reconstruction of certain curb ramps at different times to maintain accessibility. In other

cases, temporary facilities may need to be developed and included in the construction plans. See Section 55-2.01(d) for additional discussion on accommodating pedestrians/bicyclists in a traffic control plan.

58-1.02 Buildings and Facility Sites

For accessibility criteria in buildings, airport terminals, rest areas, weigh stations, and transit stations; and the sites on which they are located, use the accessibility criteria set forth in the *2010 ADA Standards for Accessible Design* and/or the *Illinois Accessibility Code*. These documents contain the accessibility requirements for interior building features including rest rooms, drinking fountains, elevators, telephones, etc.; as well as exterior features including parking, stairs, ramps, and walkways.

58-1.03 Bus Stops

The following accessibility criteria apply to the construction of bus stops:

1. **Bus Stop Pads.** Bus stop pads constructed for use in conjunction with a lift or ramp shall meet the following criteria:
 - Provide a firm, stable, and slip resistant surface.
 - Provide a minimum clear length of 96 in (2.440 m) (measured from the curb or roadway edge) and minimum clear width of 60 in (1.525 m) (measured parallel to the roadway).
 - Connect the bus stop pad to an accessible route.
 - The slope of the pad parallel to the roadway will be the same as the roadway to the maximum extent practicable.
 - For drainage, provide a desirable cross slope of 1.5% up to a maximum cross slope of 2% perpendicular to the roadway.
2. **Bus Shelters.** Where bus shelters are provided, install or position them to permit a wheelchair user to enter from the public way and reach a location within the shelter having a minimum clear floor area of 30 in by 48 in (760 mm by 1.220 m). An accessible route shall be provided from the shelter to the boarding area.

58-1.04 Parking**58-1.04(a) Off-Street Parking**

The following criteria apply to off-street disabled parking spaces:

1. Minimum Number. Figure 58-1.A provides the criteria for the minimum number of accessible spaces. A typical disabled stall layout is shown in Figure 58-1.B.
2. Location. Parking spaces for disabled individuals and accessible passenger loading zones that serve a particular building shall be the spaces or zones closest to the nearest accessible entrance on an accessible route. In separate parking structures or lots that do not serve a particular building, locate parking spaces for disabled individuals on the shortest possible circulation route to an accessible pedestrian entrance of the parking facility. In buildings with multiple access entrances with adjacent parking, accessible parking spaces may be dispersed and located closest to the accessible entrances.
3. Signing. Designate the parking spaces for the disabled with ground-mounted signs as shown in the *ILMUTCD* as sign number R7-8 with sign number R7-I101 ("Fine" placard) below. The signs shall not be obscured by a vehicle parked in the space.
4. Dimensions. The parking spaces designated for the disabled shall be a minimum 16 ft (4.9 m) wide including an 8 ft (2.4 m) access aisle. Two accessible parking spaces shall not share a common access aisle. Parking access aisles shall blend to common level with an accessible route and should be diagonally striped (*Illinois Vehicle Code, Section 11-3.01*). Parked vehicular overhangs shall not reduce the clear width of an accessible circulation route.
5. Passenger Loading Zones. Passenger loading zones shall provide an access aisle at least 60 in (1.5 m) wide and 20 ft (6.1 m) long adjacent and parallel to the vehicular pull-up space. If there are curbs between the access aisle and the vehicular pull-up space, provide a curb ramp that complies with Section 58-1.09. Vehicular standing spaces and access aisles shall be essentially level. Surface slopes shall preferably be 1.5% but shall not exceed 2% in all directions.

58-1.04(b) On-Street Parking

Where on-street paid or time-limited parking is provided and designated in areas zoned for business uses, the on-street parking design desirably should meet the following accessibility criteria:

1. Number of Spaces. Figure 58-1.A provides the criteria for the number of on-street accessibility spaces.
2. Location. On-street accessibility parking spaces should be dispersed throughout the project area. To the maximum extent feasible, locate the accessible on-street parking in level areas.

3. **Dimensions.** For a parallel parking space and where the width of the adjacent sidewalk or available right-of-way exceeds 14.0 ft (4.3 m), a 60 in (1.5 m) wide access aisle shall be provided at street level the full length of the parking space and shall connect to a pedestrian access route. This is illustrated in Figure 58-1.C. The access aisle shall not encroach into the vehicular travel lane. An access aisle is not required where the width of the adjacent sidewalk or the available right-of-way is less than or equal to 14.0 ft (4.3 m). When an access aisle is not provided, the parking spaces shall be located at the end of the block.
4. **Signing.** Designate the parking spaces for the disabled with ground-mounted signs as shown in the ILMUTCD as sign number R7-8 and include the appropriate "Fine" placard below. Locate these signs so they are visible from a driver's seat.
5. **Curb Ramps.** If there are curbs next to an on-street accessible parking space, provide a curb ramp complying with Section 58-1.09. Accessible parking spaces adjacent to intersections may be served by the sidewalk curb ramp at the intersection, provided that the path of travel from the access aisle to the curb ramp is within the pedestrian crossing area.

Total No. of Parking Spaces	Minimum Number of Accessible Spaces
1 to 25	1
26 to 50	2
51 to 75	3
76 to 100	4
101 to 150	5
151 to 200	6
201 to 300	7
301 to 400	8
401 to 500	9
501 to 1000	2% of total
1001 and over	20 plus 1 for each 100 over 1000

Notes:

- a. *If one or more passenger loading zones are provided, then at least one passenger loading zone shall comply with Item # 5 in Section 58-1.04(a).*
- b. *Parking spaces for side-lift vans are accessible parking spaces and may be used to meet the requirements of this Section.*
- c. *The total number of accessible parking spaces may be distributed among closely spaced parking lots, if greater accessibility is achieved.*

MINIMUM NUMBER OF ACCESSIBLE SPACES FOR DISABLED USERS

Figure 58-1.A

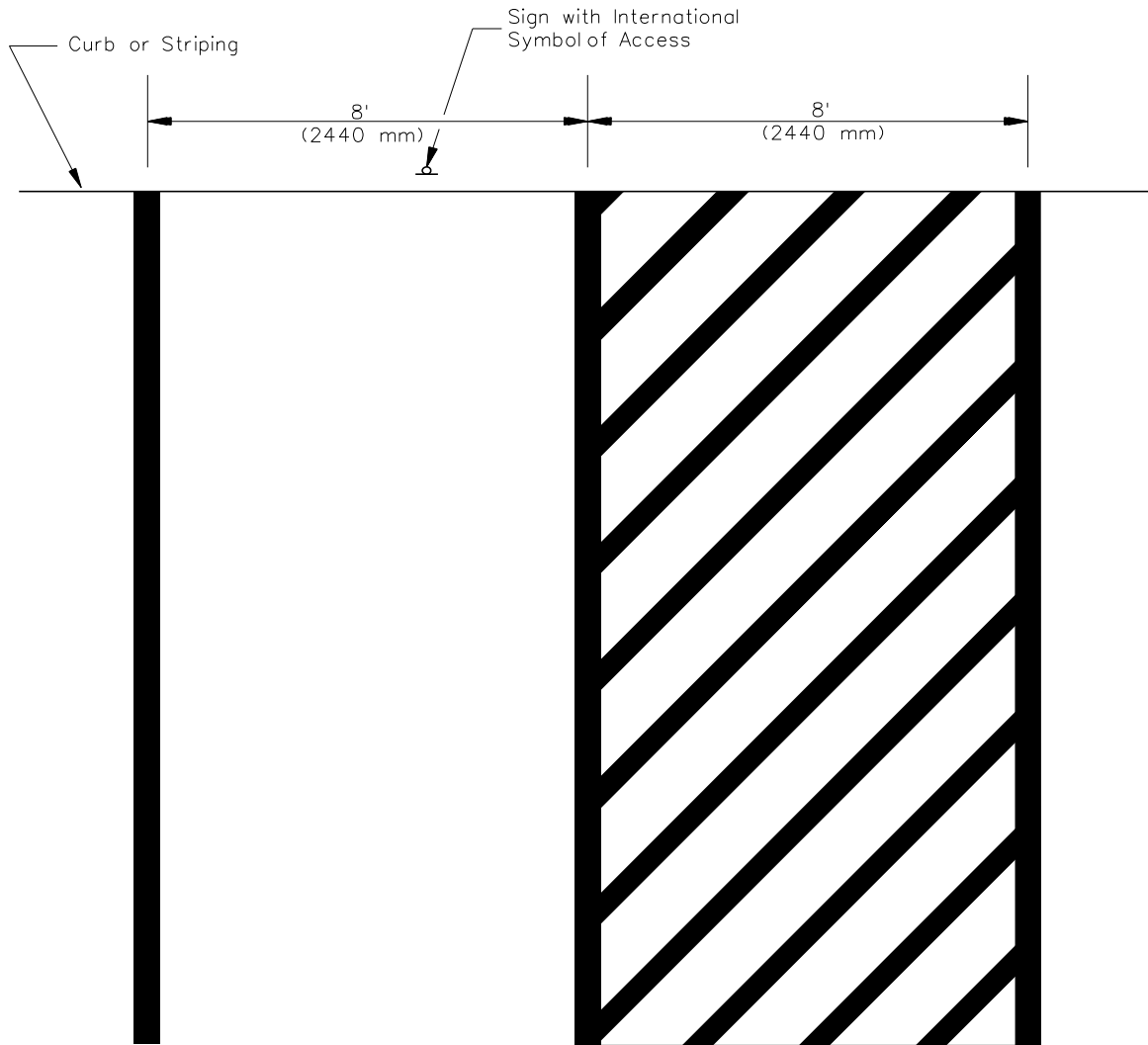

**DISABLED PARKING STALL DIMENSIONS
(Off-Street Parking)**

Figure 58-1.B

58-1.05 Accessible Route

58-1.05(a) Definition

An accessible route is a continuous, unobstructed path connecting all accessible elements and spaces. Interior accessible routes may include corridors, floors, ramps, elevators, lifts, and clear floor space at fixtures. Exterior accessible routes may include sidewalks, parking access aisles, curb ramps, crosswalks at vehicular ways, walks, ramps, and lifts.

58-1.05(b) Selecting Accessible Routes

At buildings and facility sites (airport terminals, rest areas, weigh stations, transit stations, etc.), at least one accessible route shall be provided within the boundary of the site from public transportation stops, accessible parking, accessible passenger loading zones, and public streets or sidewalks to the accessible route for the building they serve. The accessible route shall, to the maximum extent feasible, coincide with the route for the general public.

Within the public right-of-way, all routes are held to the accessible standard.

58-1.06 Sidewalks

Section 48-2.04 presents the Department's warrants and design criteria for sidewalks. The following represents the accessibility criteria:

1. Width. The typical sidewalk width is 60 in (1.5 m). The minimum width is 48 in (1.2 m).
2. Passing Spaces. If the sidewalk has less than 60 in (1.5 m) clear width, then passing spaces at least 60 in by 60 in (1.5 m by 1.5 m) shall be located at reasonable intervals not to exceed 200 ft (60 m). A T-intersection between two walks is an acceptable passing space such that the T-intersection consists of a 60 in by 60 in (1.5 m by 1.5 m) passing space. Paved driveways may also provide acceptable passing space in residential areas such that the area of the driveway used for passing does not have a cross slope perpendicular to the direction of travel greater than 2%.
3. Surface. All sidewalk surfaces shall be stable, firm, and slip resistant. The vertical alignment of the surface should be flush and free of abrupt changes. However, changes in level up to $\frac{1}{4}$ in (6 mm) are allowed without treatment. Changes in level between $\frac{1}{4}$ in and $\frac{1}{2}$ in (6 mm and 13 mm) shall be beveled with a slope no greater than 1:2. Changes greater than $\frac{1}{2}$ in (13 mm) are not allowed.
4. Horizontal Openings. Horizontal openings in gratings and joints shall not exceed $\frac{1}{2}$ in (13 mm) in the dominant direction of travel. Elongated openings in gratings shall be placed so the long dimension is perpendicular to the dominant direction of travel. Where possible, gratings should be located outside the pedestrian path of travel.

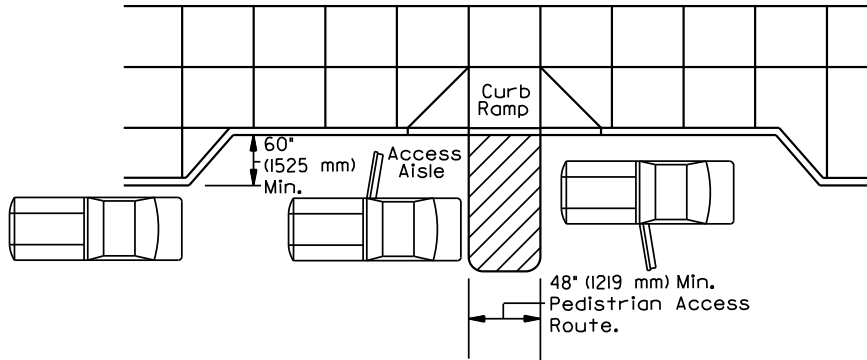

(a) Double Accessible Parking Space with Curb Ramp.

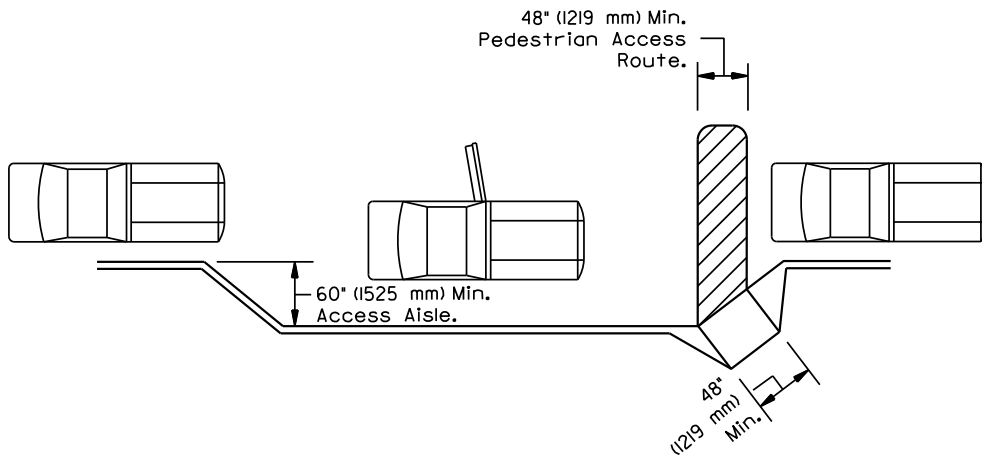

(b) Single Accessible Parking Space with Curb Ramp.

**DISABLED PARKING
(On-Street Parking)**

FIGURE 58-1.C

5. Running Slope. For sidewalks located within the street or highway right-of-way, the running slope shall not exceed the general grade established for the adjacent street or highway. For sidewalks located outside of such right-of-way, the running slope shall be 5% maximum.
6. Cross Slope. The sidewalk cross slope shall not exceed 2%. However to allow for some variation during construction and maximize the accessibility of the sidewalk, a cross slope in the range of 1.0% to 1.5% should be used. Where driveways or alleys intersect with sidewalks, give design priority to the sidewalk cross slope rather than to the grade of the driveway or alley. This may require regrading the driveway or realigning the sidewalk. Figure 58-1.D shows one example.
7. Protruding Objects. Objects projecting from walls (e.g., signs, telephones, canopies) with their leading edges between 27 in (685 mm) and 80 in (2.0 m) above the finished sidewalk shall not protrude more than 4 in (100 mm) into any portion of the sidewalk. Freestanding objects mounted on posts or pylons may overhang their mountings up to a maximum of 12 in (305 mm) when located between 27 in (685 mm) and 80 in (2.0 m) above the sidewalk or ground surface. Protruding objects less than 27 in (685 mm) or greater than 80 in (2.0 m) may protrude any amount provided that the effective clear width of the sidewalk is maintained. Where the vertical clearance is less than 80 in (2.0 m), provide a barrier to warn the blind or visually impaired person.
8. Separation. Sidewalks will be separated from roadways by curbs, planted parkways, or other barriers, which will be continuous except where interrupted by driveways, alleys, or connections to accessible elements.
9. Curb Ramps/Crosswalks. Curb ramps and crosswalks must comply with the criteria in Section 58-1.09.
10. Bridges. Bridges can present special problems for meeting the above sidewalk criteria. Due to geometric restraints of the facility being crossed, special treatments may be required; consult with BDE and the Bureau of Bridges and Structures.

58-1.07 Stairs

Stairs shall not be part of an exterior accessible route because they cannot be safely negotiated by individuals in wheelchairs. Where stairs are used, they should be designed to be accessible by other disabled individuals. Therefore, the design of stairs shall comply with Section 504 of the *2010 ADA Standards for Accessible Design*. This includes the provision of handrails.

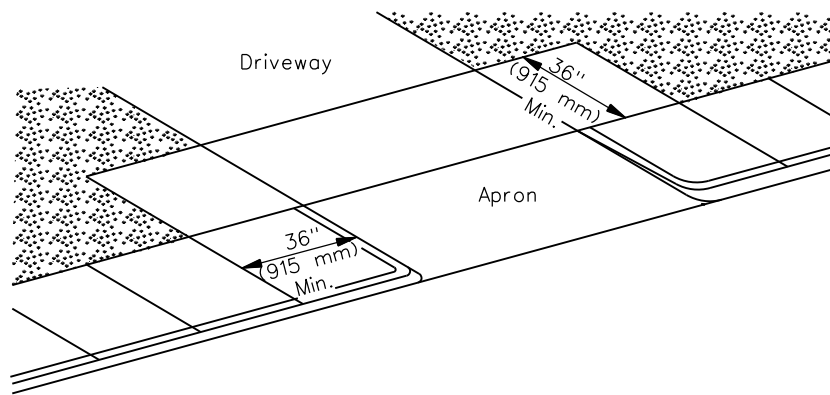

SIDEWALKS AT DRIVEWAY APRONS

Figure 58-1.D

58-1.08 Ramps

Portions of sidewalks whose running slope exceed 5% and are not following the general grade of an adjacent street or highway are considered ramps (Note: These ramps are different from curb ramps. See Section 58-1.09 for curb ramps.). The following represents the accessible criteria for ramps:

1. Running Slope and Rise. Ramps shall have a running slope greater than 5% up to an 8.3% maximum. The maximum rise for any single ramp run shall be 30 in (760 mm). For ramp heights greater than 30 in (760 mm), a series of ramps and landings must be used. Ramps to be constructed on existing building/facility sites or inside existing buildings/facilities may have a running slope which exceeds 8.3% within the rise limitations shown in Figure 58-1.E, if space limitations dictate.
2. Width. The minimum clear width of a ramp shall be 36 in (915 mm). Where handrails are provided, the clear width is measured between inside edge of the rails.
3. Landings. Ramps shall have level landings (preferably be 1.5% and no greater than 2% in all directions) at the bottom and top of each run and shall have the following features:
 - The landing shall be at least as wide as the widest ramp run leading to the landing.
 - The landing length shall be a minimum of 60 in (1.5 m).

- If ramps change direction at landings, the minimum landing size shall be 60 in by 60 in (1.5 m by 1.5 m).
4. **Handrails.** If a ramp run has a rise greater than 6 in (150 mm) or a horizontal projection greater than 72 in (1.8 m), then it shall have handrails on both sides. See the applicable accessible guidelines for additional handrail criteria.
 5. **Cross Slope and Surfaces.** The cross slope of ramp surfaces shall preferably be 1.5% and no greater than 2%. Ramp surfaces shall comply with the criteria for "Surface" of sidewalks; see Section 58-1.06.
 6. **Edge Protection.** Ramps and landings with drop-offs shall have curbs, walls, railings, or extended surfaces that prevent people from slipping off the ramp. Curbs shall be a minimum of 2 in (50 mm) high. Extended surfaces shall extend a minimum of 12 in from the outside of the handrail.
 7. **Outdoor Conditions.** Outdoor ramps and their approaches shall be designed so that water will not accumulate on walking surfaces.

Running Slope	Maximum Rise
> 8.3% but ≤ 10% (> 1:12 but ≤ 1:10)	6 in (150 mm)
> 10% but ≤ 12.5% (> 1:10 but ≤ 1:8)	3 in (75 mm)

Note 1: These dimensions may only be used when space limitations will not fit a standard ramp.

Note 2: Running slopes steeper than 12.5% (1:8) are not allowed.

**ALLOWABLE EXCEPTIONS TO STANDARD RAMP DIMENSIONS
(Existing Sites, Buildings, and Facilities)**

Figure 58-1.E

58-1.09 Curb Ramps

A curb ramp shall connect sidewalks at each pedestrian street crossing or crosswalk. For the purpose of this section, a pedestrian crosswalk is defined as that portion of a highway or street ordinarily included within the prolongation or connections of lateral lines of sidewalks at intersections. It also includes any portion of a highway or street distinctly indicated as a crossing for pedestrians by lines or other markings on the surface. It does not include such prolonged or connecting lines from an alley across a street.

58-1.09(a) Responsibility for Construction of Curb Ramps

The determination by the Department whether to construct or modify curbs and/or curb ramps is dependent upon two issues: scope of the project and jurisdiction.

1. Scope. If curbs or crosswalks will be altered as part of the State project and there is sidewalk or evidence of pedestrian usage, the Department will construct curb ramps where none exist or, if curb ramps are existing and inaccessible, reconstruct accessible curb ramps.

Resurfacing through a crosswalk is an alteration; therefore construction/reconstruction of curb ramps must be considered with 3P and SMART projects. However, if the curb ramp work requires right-of-way or the cost of the curb ramp work becomes excessive relative to the project's scope/cost, then other program categories such as 3R may be used. Another alternative for deferring curb ramp construction/reconstruction for 3P and SMART projects is to utilize a separate project exclusively for curb ramps.

2. Jurisdiction. If curbs or crosswalks will not be altered as part of a project and the Department does not have jurisdiction over the curbs, provisions for curb ramps will be the responsibility of local governments. Where curbs and crosswalks will not be altered but the Department does have jurisdiction over the curbs, curbs and inaccessible curb ramps will be reconstructed as part of the project to the maximum extent feasible.

Jurisdiction will be determined by the existence and provisions of maintenance agreements. Where written maintenance agreements do not exist, contact the Bureau of Local Roads and Streets (BLRS) or use the BLRS publication *Jurisdictional Transfer Guidelines* as the initial basis to determine the applicable jurisdictional responsibility of the highway and its elements.

58-1.09(b) Design and Construction of Curb Ramps

Curb ramps shall meet the following criteria:

1. Crosswalks. Curb ramps at marked crossings shall be wholly contained within the markings, except when flared sides are provided. The flared sides of a curb ramp may be outside of the crosswalk. At intersections where there is no marked crosswalk, place the curb ramp within the area that would reasonably be expected to be used as a crosswalk.
2. Diagonal Curb Ramps. Avoid using a diagonal curb ramp whenever practical due to its effect on the crosswalk width and the lack of way-finding they provide for users with low vision. It is preferable to use two perpendicular curb ramps or a depressed corner rather than a diagonal curb ramp.
3. Raised-Curb Medians. Where a raised-curb median exists within a crosswalk, depress the median to the level of the crosswalk. Provide detectable warning surfaces behind the back of each curb if the median opening is greater than 6 ft measured between the

- back of curbs (See the *Highway Standards*). Another option is to provide curb ramps on both sides of the median and a minimum level landing area 60 in (1.8 m) by 60 in (1.8 m) between the ramps. A level landing area shall be provided at the upper end of each ramp if the median curb ramps are not in-line.
4. Pedestrian Signals. The location of the curb ramp must be consistent with the operation of pedestrian-actuated traffic signals, if present.
 5. Cross Slope. The maximum cross slope of curb ramps shall be 2%. At pedestrian street crossings the cross slope at the bottom of the ramp shall be permitted to equal the street or highway grade.
 6. Running Slope. The running slope of a curb ramp within the public right-of-way shall be 8.3% maximum. The maximum length of a curb ramp is 15 ft (4.6 m). If a curb ramp, using an 8.3% running slope, will exceed 15 ft (4.6 m), use a steeper running slope. The running slope of a curb ramp within a building or facility site may comply with Figure 58-1.E.
 7. Flared Sides. Where a pedestrian circulation path crosses the curb ramp (that is where pedestrians can approach the curb ramp from the side), flared sides shall be provided. The flared sides shall be sloped a maximum of 10% measured parallel to the curb line. The flared sides are not considered part of the ramp width or the pedestrian access route.
 8. Width. The clear width of curb ramps within the public right-of-way shall be 48 in (1.2 m) minimum (excluding any flared sides). The clear width of a curb ramp within a building or facility site shall be 36 in (0.915 m) minimum.
 9. Grade Breaks. Grade breaks at the top and bottom a curb ramp runs shall be perpendicular to the direction of the ramp run. Grade breaks are not permitted on the surface of ramp runs or landings (turning spaces). Surface slopes that meet at grade breaks shall be flush.
 10. Landings (Turning Space). An upper landing (turning space) 48 in (1.2 m) by 48 in (1.2 m) minimum (preferably 60 in (1.5 m) by 60 in (1.5 m)) shall be located at the top of the curb ramp. An upper landing area is not required if the running slope of the curb ramp is less than 5%. The maximum slope of the landing shall not exceed 2% in all directions. Where the running slope cannot cut through the curb at right angles or meet the gutter break at right angles, provide a lower landing area to create a grade break which is perpendicular to the direction of the ramp run.
 11. Surface. The surface of a curb ramp shall be stable, firm, and slip resistant.
 12. Detectable Warnings. Detectable warnings shall be according to Section 58-1.09(d)
 13. Clear Maneuver Space. When curb ramps are not in line with the crosswalk, a clear space shall be provided beyond the bottom grade break for pedestrians to maneuver from the ramp to the crosswalk. The clear space shall be 48 in (1.2 m) minimum by 48

in (1.2 m) minimum, within the width of the pedestrian street crossing, and wholly outside the parallel vehicle lane.

58-1.09(c) Detectable Warning Surfaces

Detectable warning surfaces for curb ramps and other locations shall be according to the following:

1. General. Detectable warnings consist of a surface of truncated domes aligned in a square or radial pattern. The following criteria apply:
 - a. Dome Size and Spacing. The size and spacing of the truncated domes is shown in the various accessibility standards.
 - b. Contrast. Detectable warning surfaces shall contrast visually with adjacent walking surfaces either light-on-dark or dark-on-light.
 - c. Surface Size. Detectable warning surfaces shall extend a minimum of 24 in (600 mm) in the direction of pedestrian travel and the full width of the walking surface of the curb ramp or landing. For curb ramps with flared sides, the flared sides are not considered part of walking surface.
2. Location. Detectable warnings are required at curb ramps, medians and pedestrian refuge islands, at-grade railroad crossings, transit platform edges, and other locations where pedestrians are required to cross a hazardous vehicular way. Detectable warnings are also required where sidewalks cross alleys and commercial entrances where traffic control devices (e.g., yield signs, stop signs, or signals) are present.
 - a. Curb Ramps, Medians, and Pedestrian Refuge Islands. Locate the detectable warning surface as shown in the Highway Standards.
 - b. Rail Crossings. Locate the detectable warning surface on each side of the rail crossing and the edge of the detectable warning nearest the rail crossing shall be 6 ft (1.8 m) minimum and 15 ft (4.6 m) maximum from the centerline of the rail.
 - c. Transit Platform Edges. Detectable warning surfaces at transit platform edges are 24 in (600 mm) wide and extend the full length of the platform.
 - d. Stairs at Building and Facility Sites. Stairs, except those enclosed in stair towers or set to the side of the path of travel, shall have detectable warnings at the top of stair runs.

58-1.09(d) Crossing Controls

If a pedestrian crosswalk and curb ramp are present at an intersection with a traffic signal that has pedestrian detectors (push buttons), the following will apply: Refer to Sections 4E.08 to

4E.13 of the Illinois Manual on Uniform Traffic Control Devices for guidance on accessible pedestrian signals and pedestrian pushbuttons.

1. Location. Locate the controls as close as practical to the curb ramp and, to the maximum extent feasible, permit operation from a level area immediately adjacent to the controls.
2. Surface. Provide a firm, stable, and slip-resistant area, a minimum of 36 in by 48 in (0.915 m by 1.2 m), to allow a forward or parallel approach to the controls.

58-1.10 Pedestrian Overpasses and Underpasses

When deciding where to locate a pedestrian crossing, highway and structural designers must coordinate their efforts to properly address the accessibility considerations. The following are applicable:

1. Warrants. Threshold warrants for considering a pedestrian overpass are dependent on pedestrian volumes, vehicular volumes, and distance to the nearest “safe” alternative crossing. These warrants are determined on a case-by-case basis. Additional guidance can be found in FHWA-RD-84/082 *Warrants for Pedestrian Over and Underpasses*.
2. Accessible Route. All current and future accessible routes must be identified. If existing routes are inaccessible, the designer must evaluate the likelihood that the routes will be made accessible in the future. This evaluation may lead to the decision to relocate the pedestrian overpass or underpass to another site where accessibility can be more easily provided.
3. Design. The proposed design must meet the *accessible* criteria for stairs, ramps, curb ramps, and sidewalks. Also, reference FHWA-IP-84-6 *Guidelines for Making Pedestrian Crossing Structures Accessible* for additional design information.

58-1.11 Rest Areas

The accessibility guidelines referenced in Section 58-1.02 address the features present at rest areas. However, certain features need further clarification:

1. Picnic Areas. Where picnic areas/tables are provided in accessible or common use areas, at least 5%, but not fewer than one, of the picnic areas/tables shall be accessible. An accessible route shall lead to and through such picnic areas or tables. Signs displaying the international symbol of accessibility should be erected at those locations which include accessible facilities.
2. Separator Islands. Many rest areas include islands to separate passenger vehicle parking areas from truck parking areas. In many cases, disabled persons travel in vehicles that may have to park in the truck parking area. In addition, many tour buses use these areas. Accordingly, provide an opening in the island as discussed for “Raised

Curb Medians” in Section 58-1.09(c) to provide accessibility for the disabled. Also, consider special markings or signing to indicate the location of this opening.

3. Parking. Provide the minimum number of disabled parking spaces per Figure 58-1.A in both automobile and truck parking areas. See Chapter 16 for additional design criteria.

58-2 OFF-STREET PARKING

A proposed highway project may incorporate some form of off-street parking. Typical applications may include:

- providing off-street parking to replace on-street parking which will be removed as part of a proposed project;
- the construction of a park-and-ride lot for commuters; or
- the construction of a new rest area or improvement to an existing rest area.

58-2.01 Park-and-Ride Lots

58-2.01(a) Location

Park-and-ride lots may be located in either rural or urban areas to accommodate car-pooling or to provide access to transit terminals. By locating these lots outside of the downtown area, congestion is reduced, parking lot property costs are lowered, and accessibility is improved. The general location and size of park-and-ride lots is normally determined during Phase I. Guidance for site selections can be found in the *AASHTO Guide for the Design of Park-and-Ride Facilities*. Some of the factors that will affect the location of the parking facility include:

1. Site Availability. Park-and-ride lots may consist of publicly owned property, excess State right-of-way, or property used with the permission of private owners. When reviewing sites, consider the long-term availability of the lot.
2. Accessibility. The lot should be convenient to residential areas, bus and rail transit routes, and major highways used by commuters.
3. Visibility. The park-and-ride lot should be visible from the access road.
4. Demand. The lot must be large enough to accommodate the anticipated demand for parking spaces. In addition, sufficient transit service must be available to accommodate the anticipated demand.
5. Congestion. The location should precede any points of congestion on the major commuting highway to maximize its benefits.
6. Capacity. There should be sufficient capacity on connections between the lot and the major commuting highway.
7. Design. The site location must be compatible with the design and construction of the lot. Considerations will include property costs, terrain, drainage, subgrade soil conditions, and available space in relation to the required lot size, visibility, and access.
8. Land Use. The location of the lot should be consistent with the present and future adjacent land use. Consider the lot's visual and other impacts on surrounding areas.

Where necessary, site sizing and design should allow for buffer landscaping to minimize the visual impact.

58-2.01(b) Layout

Consider the following when laying out a park-and-ride facility:

1. Entrances and Exits. Locate entrances and exits so that they have the least disruption to existing traffic on the street, allow easy access to and from the lot, and provide the maximum storage space within the lot. In addition, consider the following:
 - a. Location. Provide separated entrances and exits whenever practical, preferably on two or more streets. The entrance should be on the “upstream” side of the traffic flow nearest the lot and the exit on the “downstream” side. If separation is not reasonable, the combined entry-exit point should be as close to mid-block as practical.
 - b. Spacing. Separate entrances and exits should be at least 150 ft (45 m) apart and 150 ft (45 m) from a public road intersection. Desirably, these distances should be 300 ft (100 m). For lots with less than 150 spaces, these dimensions may be reduced to 100 ft (30 m).
 - c. Traffic Signals. If a traffic signal is warranted or is expected in the future, the entrance should be more than 1200 ft (400 m) from an adjacent signal. Ensure that the traffic signal can be interconnected and/or coordinated with the other traffic signals to allow vehicular progression along the route.
 - d. Storage. Ensure that there is sufficient storage on the mainline for entering the lot. This may require providing separate left- and/or right-turn lanes. Also, check the exiting traffic to ensure that the exiting queue will not adversely affect the traffic circulation in the lot itself.
 - e. Design. Design all entrances and exits for capacity, sight distance, turning radii, acceleration and deceleration lanes, turn lanes, etc., according to the criteria in Chapter 36. The typical design vehicle will be a BUS.
2. Drop-off/Pick-up Zones (Kiss-and-Ride). Drop-off and pick-up zones for buses and autos should be clearly separated from each other and from parking areas to avoid as many internal traffic conflicts as possible. Circulation for kiss-and-ride facilities should be one-way and adjacent to the terminal loading/unloading area. Angle the parking at 45° towards the loading terminal to allow vehicles to pull through.
3. Traffic Circulation. Arrange the traffic circulation to provide maximum visibility and minimum conflict between small vehicles (e.g., autos, taxis) and large vehicles (e.g., large vans, buses). Locate major circulation routes at the periphery of the lot to minimize vehicular-pedestrian conflicts. A counter-clockwise circulation of one-way traffic is preferred. This allows vehicles to unload from the right side.

4. Pedestrian and Bicyclist Considerations. Consider pedestrian and bicycle routes when laying out the commuter lot. Avoid entrance and exit points in areas with high-pedestrian volumes, if practical. Provide sidewalks between the parking areas and the modal transfer points. Locate passenger waiting areas in a central location or near the end of the facility. Maximum walking distances to any loading area should not exceed 1000 ft (300 m). Longer walking distances may require more than one loading area.

Crosswalks should be provided where necessary and be clearly marked and signed. Include signing and pavement markings for all pedestrian and bicycle paths to eliminate indiscriminate movements. In high-volume lots, fencing, barriers, or landscaping may be warranted to channel pedestrians and bicyclists to appropriate crossing points. Crossings at major two-way traffic circulation lanes should have a refuge island separating the travel directions.

Include a bicycle parking area relatively close to the loading area. If a large volume of bicycle traffic is expected, provide a designated bicycle lane to and from the bicycle parking area.

5. Accessibility for Disabled Individuals. Section 58-1 discusses the accessibility criteria for disabled individuals, which also apply to park-and-ride lots.

58-2.02 Replacement Parking Guidelines

In general, on-street parking should be discouraged due to their inherent hazards and capacity problems. Review the following when considering removing on-street parking:

1. Implementation. Ensure that early involvement coordination is conducted with the affected municipality to determine any significant social, economic, and environmental effects from both parking removal and replacement. Discuss existing parking patterns to determine replacement requirements based on actual needs rather than the existing number of available spaces. This information should be included in the Phase I report, combined with estimated costs for parking replacement. Replacement off-street parking may be let as part of the roadway improvement or as a separate municipal contract.
2. Participation. The Department will provide 100% of all engineering, right-of-way (except where replacement parking is constructed on municipally owned property), and construction costs required to construct alternative (off the State system) parking on a maximum ratio of 1 to 1. Alternative parking can consist of improving adjacent local streets to provide some parallel parking, the construction of off-street parking facilities, or combinations thereof. Construction costs will include those items the Department deems reasonable to provide parking facilities including a paved surface, drainage, lighting, pedestrian walkways, and fencing. The construction and installation of guard and toll collection facilities, metering devices, and parking capacity beyond the maximum replacement ratio will be the municipality's responsibility.

3. Maintenance. Provide an agreement with the municipality which allows them to accept jurisdiction of the parking facility including but not limited to its maintenance, operation, repair, reconstruction, provision of electrical energy for lighting systems, and striping. See Chapter 5 for information on local agreements. The municipality will hold the State harmless from any suits arising from construction, operation, and maintenance of these parking facilities.
4. Right-of-Way. The municipality will be responsible for acquiring all necessary rights-of-way and easements in its own name and will provide the Department with certification that it holds good and sufficient title to these properties. This will include the following:
 - a. Hazardous Waste Survey. The Department will, at its own expense, conduct a survey for potential hazardous wastes and notify the municipality of its acceptance or rejection of the site.
 - b. Site Purchase. The municipality will follow the procedures contained in IDOT's *Land Acquisition Manual* and provide the Department with an estimate of right-of-way costs, including its purchase price plus fees associated with negotiators, appraisals, title evidence, and legal services for each potential parcel. The Department will be allowed to either accept or reject the parcel(s).
 - c. Municipally Owned Site. If the municipality owns the site selected for replacement parking, it will provide the property at no expense to the Department. The cost of clearing the municipally owned property will be the Department's responsibility and will be included in the construction contract.
5. Enforcement. The municipality will be responsible for enacting and enforcing ordinances prohibiting parking at all locations where on-street parking is removed.
6. Ownership. The municipality will, unless otherwise approved by the Department in writing, retain in public trust for a period of at least 20 years, all parking facilities constructed at State expense. If the municipality wishes to remove itself from this agreement, the Department will not unreasonably withhold such approval but will require pro rata compensation for its initial expense in constructing the parking facilities as a condition of its approval.

58-2.03 Design Elements

Consider the following elements in the design of off-street parking lots:

1. Parking Lot Dimensions. Parking stall dimensions vary with the angle at which the parking space is arranged relative to the aisle. Figure 58-2.A provides the design dimensions for 9 ft x 18.5 ft (2.7 m x 5.6 m) parking stalls and shows how stalls may be combined into a parking lot. From a traffic operations standpoint, one-way aisles are desirable and should be designed to provide counterclockwise circulation. When determining parking stall widths, consider the following:

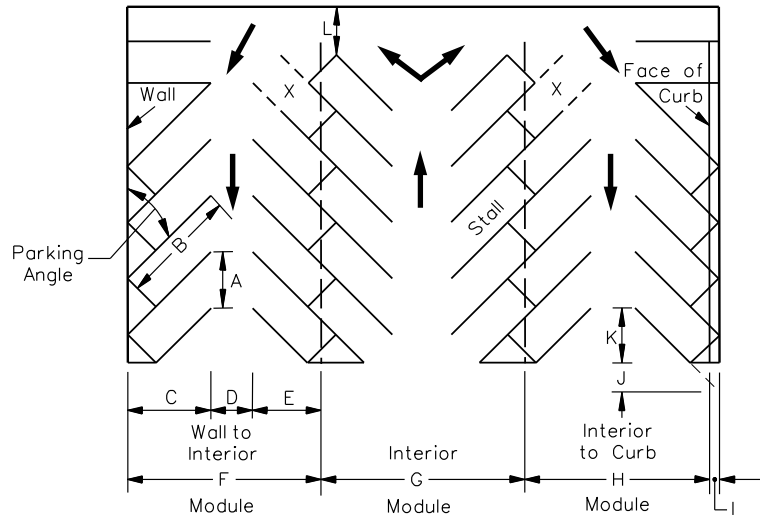

X = Stall not accessible in certain layouts

Parking Layout Dimension for 9 ft x 18.5 ft (2.7 m x 5.6 m) Stalls at Various Lengths

Design Feature	Notation	Parking Angle							
		45° (ft)	45° (m)	60°(ft)	60° (m)	75° (ft)	75° (m)	90° (ft)	90° (m)
Stall width, parallel to aisle	A	12.7	3.9	10.4	3.2	9.3	2.8	9.0	2.7
Stall length of line	B	25.0	7.6	22.0	6.7	20.0	6.1	18.5	5.6
Stall depth to wall	C	17.5	5.3	19.0	5.8	19.5	5.9	18.5	5.6
Minimum aisle width between stall lines	D	12.0	3.7	16.0	4.9	23.0	7.0	26.0	7.9
Stall depth, interior	E	15.3	4.7	17.5	5.3	18.8	5.7	18.5	5.6
Module, wall to interior	F	44.8	13.7	52.5	16.0	61.3	18.7	63.0	19.
Module, interior	G	42.6	13.0	51.0	15.5	61.0	18.6	63.0	2
Module, interior to curb face	H	42.8	13.1	50.2	15.3	58.8	17.9	60.5	19.
Bumper overhang (typical)	I	2.0	0.6	2.3	0.7	2.5	0.8	2.5	2
Offset	J	6.3	1.9	2.7	0.8	0.5	0.2	0.0	18.
Setback	K	11.0	3.4	8.3	2.5	5.0	1.5	0.0	4
Cross aisle, one-way	L	14.0	4.3	14.0	4.3	14.0	4.3	14.0	0.8
Cross aisle, two-way	—	24.0	7.3	24.0	7.3	24.0	7.3	24.0	0.0
									0.0
									4.3
									7.3

- Notes:
1. See Section 58-1 for criteria on the number and dimensions of parking spaces for disabled individuals.
 2. If a special section is designated for subcompact vehicles, these stalls can be 8 ft x 15 ft (2.5 m x 4.6 m) for a 90° angle.
 3. Stalls should be wider for commercial parking.
 4. The designer should consider bumper overhang when placing lighting, railing, etc. Therefore, these appurtenances should be placed beyond dimension "I" in the figure.
 5. Two-way traffic in aisles may only be used with a 90° parking angle. Use an aisle width of 26 ft (7.9 m).

**PARKING LOT LAYOUT DIMENSIONS
(9 ft x 18.5 ft (2.7 m x 5.6 m) Stalls)**

Figure 58-2.A

- Typical stall widths (measured perpendicular to the vehicle when parked) range from 8.5 ft to 9.5 ft (2.6 m to 2.9 m).
 - The recommended minimum stall width for self-parking of long-term duration is 9.5 ft (2.6 m).
 - For higher turnover self-parking, a stall width of 9 ft (2.7 m) is recommended.
 - Stall widths at supermarkets and other similar parking facilities, where large packages are prevalent, should desirably be 9.5 ft (2.9 m) or even 10 ft (3.0 m) in width.
2. Bus Loading Areas. Bus loading and unloading areas located adjacent to park-and-ride lots should be designed to provide for continuous counterclockwise circulation and for curb parking without backing maneuvers. The through traffic lanes and the curb loading area should each be 12 ft (3.6 m) wide. Figure 58-2.B provides criteria for the recommended lengths of bus loading areas.
 3. Sidewalk Dimensions. All sidewalks should be at least 5 ft (1.5 m) wide. In loading areas, the width should be 12 ft (3.6 m) or the adjacent sidewalk width plus 7 ft (2.1 m), whichever is greater. The accessibility criteria for the disabled must be met for all new lots; see Section 58-1.
 4. Cross Slope. To provide proper drainage, the minimum cross slope on a parking lot should be 1%. As a maximum, the cross slope should not exceed 5%. Desirably, design the lot to direct the drainage runoff into existing drainage systems. If water impoundment cannot be avoided along pedestrian routes, bicycle routes, and standing areas, provide drop inlets and underground drainage. In parking areas, design the drainage to avoid standing water. The detailed drainage design for the lot should be prepared using the Department's *Drainage Manual* to determine design frequency, pavement discharge, and capacity of drainage inlets.
 5. Pavements. Minimum pavement design for parking areas in a park-and-ride lot is 3 in (75 mm) of bituminous concrete on 8 in (200 mm) of aggregate base. For bus routes, the minimum pavement design should be 5 in (125 mm) of bituminous concrete on 10 in (250 mm) of aggregate base. For additional information on pavement designs, see Chapter 54.
 6. Lighting. Desirably, the lot should be lighted for pedestrian safety and lot security. Ensure provisions are considered for lighting supports and power lines. Chapter 56 provides information on the design of lighting.
 7. Shelters. Pedestrian shelters are desirable when loading areas for buses and trains are provided. Their inclusion will be determined on a case-by-case basis. The shelter should provide approximately 5 ft² (0.5 m²) of covered area per person. As a minimum, the shelter should provide lighting, benches, and trash receptacles. Routing information signs and a telephone should also be considered.

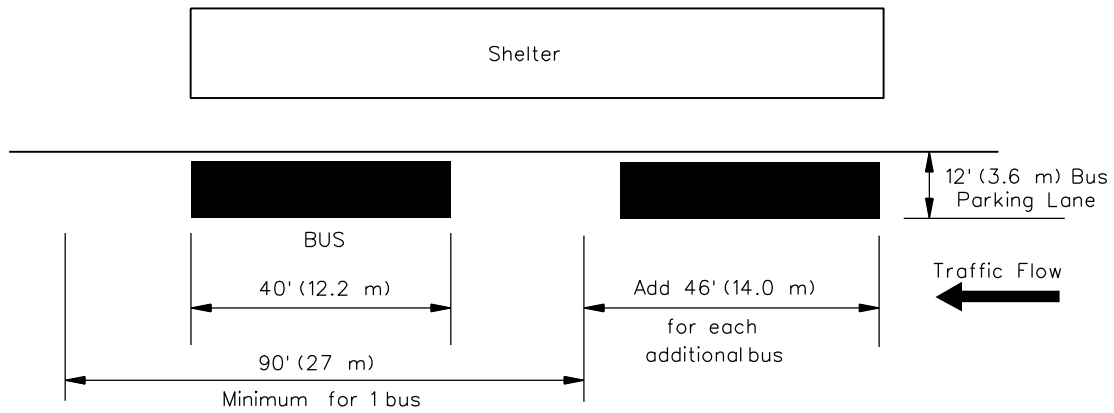

PARALLEL PARKING

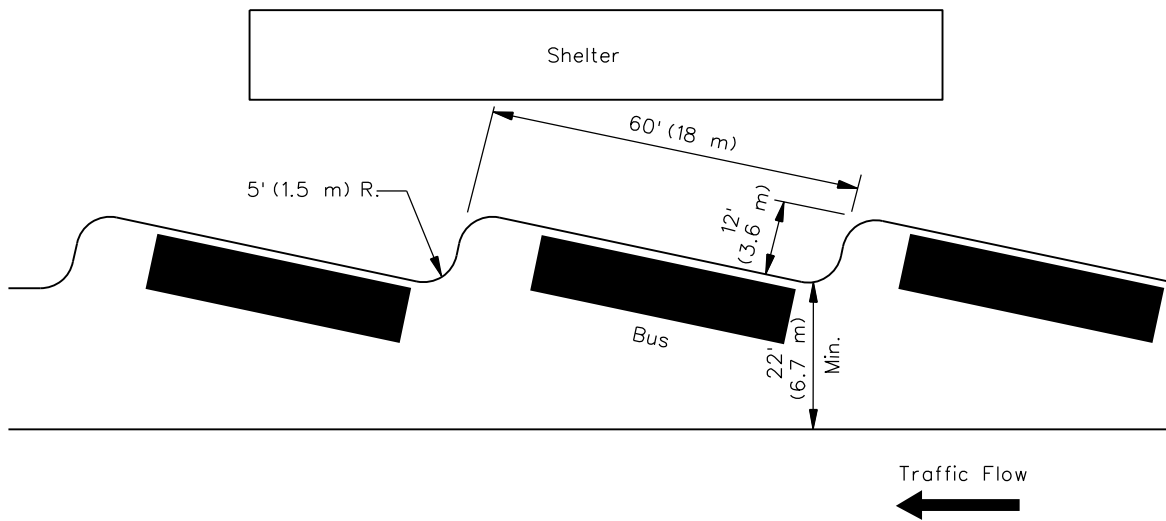

SHALLOW SAWTOOTH PARKING

**RECOMMENDED LENGTHS FOR BUS-LOADING AREAS
(Park-and-Ride Lots)**

Figure 58-2.B

8. Bicycle and Motorcycle Storage. Provide bicycle stalls that allow the use of locking devices. Bicycle stalls are typically 2 ft by 6 ft (600 mm by 1.8 m). Motorcycle stalls are 3 ft by 6 ft (1 m by 1.8 m).
9. Traffic Control Devices. Provide signs and pavement markings to direct drivers and pedestrians to appropriate loading zones, parking areas, bicycle facilities, disabled parking, and entrances and exits. Coordinate the use of traffic control devices with the district Bureau of Operations.
10. Fencing. The need for fencing around a parking lot will be determined on a case-by-case basis.
11. Landscaping. In some locations, consider landscaping to minimize the visual impact of the parking lot. This may include providing a buffer zone around the perimeter of the lot or improving the aesthetics of the lot itself. Desirably, include a 10 ft to 20 ft (3.0 m to 6.0 m) buffer zone around the lot to accommodate vegetation screens. Also, raised-curb islands and parking lot separators provide suitable locations for shrubs and trees. Landscaping should include low maintenance vegetation that does not cause visibility or security problems. See Chapter 59 for guidance on landscaping.
12. Snow Removal. To assist with snow removal and storage, the design should include a 10 ft to 20 ft (3.0 m to 6.0 m) snow shelf around the perimeter of the lot on at least two sides. This area can coincide with the buffer zone around the lot, provided that the entire area is not filled with shrubs or trees. Place any fencing outside the area of the snow shelf. Providing painted islands rather than raised-curb islands can also make it easier to plow snow from the parking lot.

58-3 BUS STOPS AND TURNOUTS

58-3.01 Location

58-3.01(a) Bus Stops

If local bus routes are located on an urban or suburban highway, the designer should consider their impact on normal traffic operations. The stop-and-go pattern of local buses will disrupt traffic flow, but certain measures can minimize the disruption. The location of bus stops is particularly important. These are determined not only by convenience to patrons, but also by the design and operational characteristics of the highway and the roadside environment. If the bus must make a left-turn, for example, do not locate a bus stop in the block preceding the left turn.

There are three basic bus stop designs — far-side or near-side of an intersection, and mid-block. Advantages and disadvantages for each of these bus-stop locations are listed in Figure 58-3.A. In addition, consider the following:

1. Far-Side Stops. For capacity and other reasons, far-side stops are generally preferred to near-side or mid-block bus stops.
2. Near-Side Stops. Near-side stops must be used where the bus will make a right turn at the intersection.
3. Mid-Block Stops. Mid-block bus stops may be considered where right turns at an intersection are high (250 in peak hour) and far-side stops are not practical.

58-3.01(b) Bus Turnouts

Interference between buses and other traffic can be reduced significantly by providing bus turnouts. Turnouts remove stopped buses from the through lanes and provide a well-defined user area for bus stops. Consider bus turnouts where the following conditions exist:

- The street provides arterial service with higher speeds (e.g., posted speeds of 35 mph or greater).
- Bus volumes are 10 or more during the peak-hour.
- Passenger volumes exceed 20 to 40 boardings an hour.
- The average bus dwell time generally exceeds 30 seconds per stop.
- During peak-hour traffic, there are at least 250 vehicles per hour in the curb lane.
- Buses are expected to layover at the end of the trip.
- Potential vehicular/bus conflicts warrant the separation of transit and other vehicles.

	Advantages	Disadvantages
Far-Side Stop	<ul style="list-style-type: none"> Minimizes conflicts between right-turning vehicles and buses. Provides additional right-turn capacity by making the curb lane available for traffic. Minimizes sight distance problems on approaches to the intersection. Encourages pedestrians to cross behind the bus. Creates shorter deceleration distances for buses because the bus can use the intersection to decelerate. Results in bus drivers being able to take advantage of the gaps in traffic flow that are created at signalized intersections. 	<ul style="list-style-type: none"> Multiple stopped buses may block the intersection during peak periods. May obscure sight distance for crossing vehicles. May increase sight distance problems for crossing pedestrians. Can cause a bus to stop twice, first for the traffic signal and then for the far-side stop, which interferes with both bus operations and all other traffic. May increase number of rear-end accidents because drivers do not expect buses to stop again after stopping at a red signal. Could result in traffic queued into intersection when a bus is stopped in travel lane.
Near-Side Stop	<ul style="list-style-type: none"> Minimizes interference when traffic is heavy on the far side of the intersection. Allows passengers to access buses closest to crosswalk. The width of the intersection allows easier re-entry into the traffic stream where curb parking is allowed. Eliminates the potential of double stopping. Allows passengers to board and alight while the bus is stopped at a red signal. Provides driver with the opportunity to look for oncoming traffic, including other buses with potential passengers. 	<ul style="list-style-type: none"> Increases conflicts with right-turning vehicles. May result in stopped buses obscuring curbside traffic control devices and crossing pedestrians. May cause sight distance to be obscured for cross vehicles stopped to the right of the bus. May block the through lane during peak period with queuing buses. Increases sight distance problems for crossing pedestrians.
Mid-Block Stop	<ul style="list-style-type: none"> Minimizes sight distance problems for vehicles and pedestrians. May result in passenger waiting areas experiencing less pedestrian congestion. Desirable if a large generator is located mid-block. Less walking for passengers where the distance between intersections is large. May be appropriate where there is a fairly heavy and continuous transit demand throughout the block. 	<ul style="list-style-type: none"> Requires additional distance for no-parking restrictions. Encourages patrons to cross street at mid-block (jaywalking). Increases walking distance for patrons crossing at intersections.

COMPARISON OF BUS STOP LOCATIONS

Figure 58-3.A

- There is a history of traffic and/or pedestrian crashes that can be resolved by a bus turnout.
- Right-of-way width is sufficient to prevent adverse impact on sidewalk pedestrian movements.
- Curb parking is prohibited, at least during peak hours.
- Sight distances prevent traffic from stopping safely behind the bus.
- Appropriate bus signal priority treatment exists at the intersection.
- Other improvements (e.g., widening) are planned for the major roadway.

58-3.01(c) Selection

In general, the municipality or local transit authority will determine the location of the bus stop or bus turnout. However, the designer usually has some control over the best placement of a bus stop or turnout location when considering layout details, intersection design, and traffic flow patterns.

58-3.02 Design

58-3.02(a) Bus Stops

Figure 58-3.B provides the recommended distances for the prohibition of on-street parking near bus stops.

58-3.02(b) Bus Turnouts

Desirably, the total length of a bus turnout will allow for an entrance taper, a deceleration length, a stopping area, an acceleration length, and an exit taper. Figure 58-3.C illustrates the design details for bus turnouts. Providing separate deceleration and acceleration lengths are desirable in open suburban area and on rural arterials and may be provided, wherever feasible. However, common practice is to accept deceleration and acceleration in the through lanes and only build the tapers and stopping area. In addition, consider the following:

1. Far-Side Turnouts. Typically, far-side intersection placement is desirable. Placing turnouts after signal-controlled intersections allows the signal to create gaps in traffic.
2. Near-Side Turnouts. Avoid using near-side turnouts because of conflicts with right-turning vehicles, delays to transit services as buses try to re-enter the traveled way, and obstructions to traffic control devices and pedestrian activities.

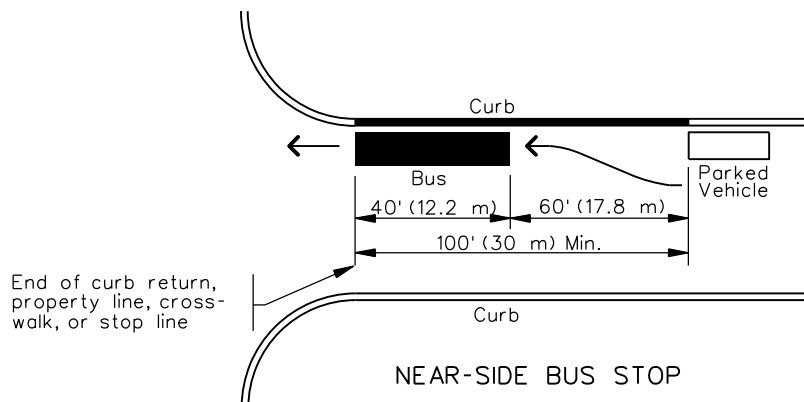
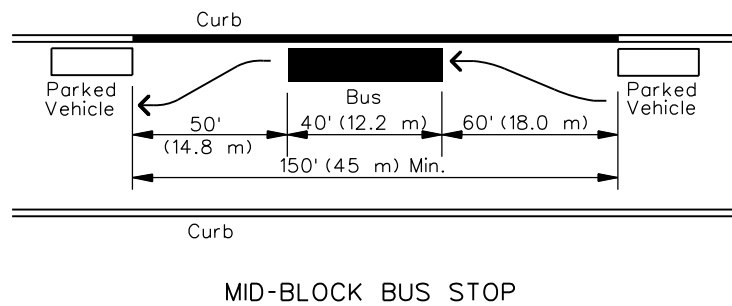
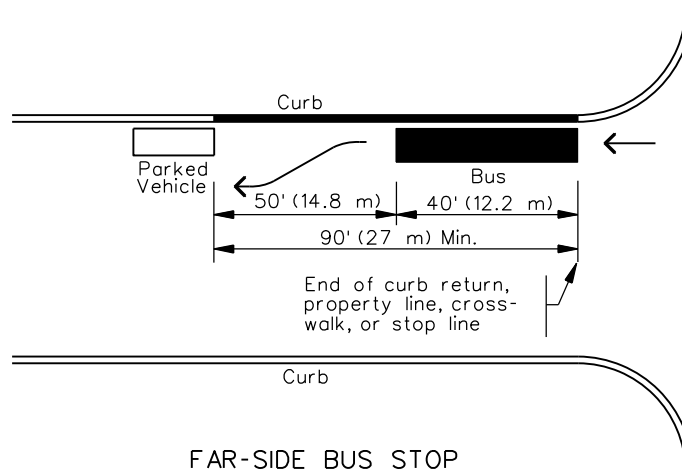

Notes:

1. Where articulated buses are expected to use these stops, add an additional 20 ft (6 m) to the bus distances.
2. Provide an additional 50 ft (15 m) of length for each additional bus expected to stop simultaneously at any given bus stop area. This allows for the length of the extra bus (40 ft (12.2 m)) plus 10 ft (2.8 m) between buses.

ON-STREET BUS STOPS

Figure 58-3.B

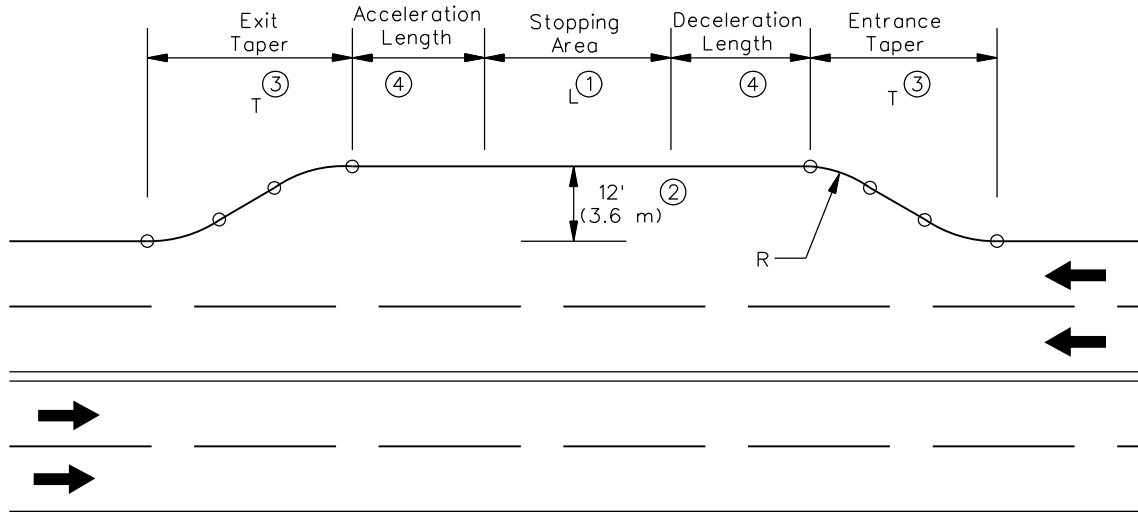

Notes:

- ① Stopping area length consists of 50 ft (15 m) for each standard 40 ft (12.2 m) bus and 70 ft (21 m) for each 60 ft (18.3 m) articulated bus expected to be at the stop simultaneously.
- ② Bus turnout width is desirably 12 ft (3.6 m). For posted speeds under 30 mph, a 10 ft (3.0 m) minimum bay width is acceptable. These dimensions do not include gutter width.
- ③ Suggested taper lengths are listed below. A minimum taper of 5:1 may be used for an entrance taper from an arterial street for a bus turnout while the merging or re-entry taper should not be sharper than 3:1.
- ④ The minimum design for a bus turnout does not include acceleration or deceleration lengths. Recommended acceleration and deceleration lengths are listed below.

Design Speed	Entering Speed*	Acceleration Lengths	Deceleration Lengths **	Suggested Taper Lengths
US CUSTOMARY				
35 mph	25 mph	250 ft	185 ft	170 ft
40 mph	30 mph	400 ft	265 ft	190 ft
45 mph	35 mph	700 ft	360 ft	210 ft
50 mph	40 mph	975 ft	470 ft	230 ft
METRIC				
50 km/h	35 km/h	60 m	45 m	45 m
60 km/h	45 km/h	105 m	70 m	50 m
70 km/h	55 km/h	200 m	105 m	60 m
80 km/h	65 km/h	310 m	145 m	70 m

* Desirably, the bus speed at the end of taper should be within 10 mph (15 km/h) of the design speed of the traveled way.

** Based on a 2.5 mph/sec (4.0 km/h/s) deceleration rate.

TYPICAL BUS TURNOUT DIMENSIONS

Figure 58-3.C

3. Mid-Block Turnouts. Only use mid-block turnouts in conjunction with major traffic generators.
4. Tapers. Figure 58-3.C provides information on taper lengths that may be used for entrance and exit tapers. To improve traffic operations, use short horizontal curves (100 ft (30 m) radius) on the entry end and 50 ft to 100 ft (15 m to 30 m) curves on the re-entry end. Where a turnout is located at a far-side or near-side location, the cross street area can be assumed to fulfill the need for the exit or entry area, whichever applies.

58-3.02(c) Bus Stop Pads

All new bus stops which are constructed for use with lifts or ramps must meet the disabled accessibility criteria in Section 58-1.

58-3.02(d) Bus Shelters

In general, the municipality or the local transit authority will determine the need for and location of bus shelters. The local transit authority will determine the design of the bus shelter. The designer should ensure that the shelter does not restrict vehicular sight distance, pedestrian flow, or disabled accessibility.

58-4 FENCING

Fencing is desirable along high-speed highways to protect the driver from unexpected intrusions from outside of the right-of-way line. Fencing deters unauthorized and unsafe entry to the highway by vehicles, pedestrians, or animals. It also reduces the occurrence of objects being dropped or thrown from highway overpasses.

Except where warranted for highway applications, fencing is normally the responsibility of the abutting property owner. Fences may be necessary for retaining livestock, discouraging trespassing, defining property boundaries, or otherwise to keep land use activities within bounds. If private fences are impacted by a highway project, their relocation or disposition is reconciled as part of the right-of-way negotiations and settlement.

58-4.01 General

58-4.01(a) Location

Fencing is typically provided along all segments of fully access controlled facilities; along certain segments of expressways; near schools, playgrounds, and parks; near livestock areas; on some bridges; and between frontage roads and access controlled highways. Fencing is usually erected parallel to the highway centerline. Where right-of-way lines are irregular, the fencing should still be basically parallel to the highway, provided the fencing is within the highway right-of-way. In general, the fence line should coincide with the right-of-way line; however, deviations are acceptable if justified and documented in a Phase I report. Avoid sharp jogs in the fence line to prevent the need for hand mowing. See Section 34-5 and Chapters 35, 44, and 45 for additional guidance on setting right-of-way limits and for the location of access control lines.

58-4.01(b) Fence Types

The following fence types are used by the Department:

1. Woven Wire. This fence type consists of a woven wire mesh and two strands of barbed wire at the top for a total height of 4 ft (1.2 m). It can be placed on either wood or metal posts.
2. Chain Link. Chain link fence consists of an interlocking wire mesh on metal posts. It is typically 4 ft (1.2 m) or 6 ft (1.8 m) high.
3. Existing. Where a portion of an existing fence, which differs from the standard type or height, is to be replaced, the new fence should match the portion of the fence that will remain in place.

All materials and installations must conform to the requirements in the *Illinois Standard Specifications* and the *Highway Standards*.

58-4.02 Freeways (Fully Access Controlled)

The following will apply to fencing along freeways:

1. Warrants. Chain link or woven wire fencing is required along all fully access controlled facilities. Provide continuous fencing along either the right-of-way or access control lines. Also, provide fencing for the entire limits of access control along the crossroad and along the first access connection. However, engineering judgment may dictate exceptions. In addition, where retaining walls, concrete barriers, sound barriers, sight screens, etc., are used, fencing usually is not required to preserve access control. With the appropriate fence inserts, the access-control fencing also may be used as a glare screen between frontage roads and the mainline highway.
2. Location. Fences generally will be located to coincide with the right-of-way line, except for the following:
 - a. Frontage Roads and Service Drives. Where frontage roads or service drives exist or will be constructed, place the fencing between the adjacent roadway and the freeway or ramps. Fencing is normally located outside the clear zone of a freeway; see Figures 44-2.J and 44-2.K. Where access control fencing is located between a frontage road or service drive and the freeway, it is not necessary to provide fencing outside the right-of-way line of the frontage road.
 - b. Structures. Wherever streams, railroads, or grade separations are encountered that prevent the fence from being continued on a straight line, tie the fence to the structure, abutment, or wingwall to ensure that full access control is maintained. See the figures in Section 44-3 for locations of access control lines adjacent to these features. See the *Highway Standards* for the correct application of fencing across stream crossings with culverts.
 - c. Outside Ditches. In relatively flat areas (e.g., across floodplains), it may be desirable to place the access control fence on the front slope of the highway embankment rather than at the right-of-way line. Placing the fence on the front slope eliminates the potential problem of obstructing sheet flow if the fence is placed along the right-of-way line. The obstruction of sheet flow is usually caused by vegetation build-up along the fence and due to field plowing adjacent to the fence.
3. Type of Area. The following will apply:
 - a. Built-Up Areas. Chain link fencing is generally used in urban, suburban, and other similar built-up areas. Use 6 ft (1.8 m) high chain link fence in areas having a high concentration of children (e.g., schools, churches, playgrounds, housing developments). Use 4 ft (1.2 m) high chain link fence in areas adjacent to single-family homes, parks, reservoirs, commercial and industrial properties, etc. The designer must consider the type of impending development adjacent to the

highway to determine the appropriate height. This may require a higher fence to be installed initially to preclude replacement a short time later.

- b. Rural Areas. In rural areas where little development is existing or planned, woven wire fencing is typically used.
 - c. Deer Crossings. Where known deer crossings exist, use a woven wire fence with a minimum height of 10 ft (3.0 m). Also, the limits of this fence must be long enough to deter deer from going around the fence. Connect the fence directly to the wingwalls of structures to minimize deer intrusions onto the highway.
4. Construction. Construct access control fencing on the State right-of-way line with the face of the fencing toward the abutting property. Delineate this location on the contract plans. The fence will be maintained by the State.
 5. Gates. Where they are considered necessary for maintenance and operational purposes, gates may be required in the access-control fencing. Limit the number of these gates to an absolute minimum. Only provide gates to allow access for:
 - maintenance to otherwise inaccessible portions of the highway right-of-way, and
 - public utility installations where no other access is available or can be reasonably provided.

All gates must have adequate locking devices to ensure that they are only used by authorized personnel. The district is responsible for maintaining a record of all personnel that possess keys to the locked gates.

58-4.03 Expressways (Partial Access Control)

The following will apply to fencing along expressways:

1. Warrants. Fencing is highly desirable along expressways similar to freeways. At a minimum, existing fencing should be replaced in rural areas and should be considered in built-up residential areas in rural locations. Where it is decided that fencing may be omitted in rural areas, provide informational signs at approximately ¼ mile (400 m) intervals on the right-of-way lines to notify the public that the highway is access controlled. The signs should indicate that the Illinois Department of Transportation may be contacted for any requests for new access points. Also, to minimize future access problems along crossroads, provide fencing along the entire access control limits of each crossroad.
2. Location. The criteria in Section 58-4.02 for freeways also applies to expressways.
3. Type of Area. The criteria in Section 58-4.02 for freeways also applies to expressways with the exceptions noted above in Item 1.

4. Construction. The criteria in Section 58-4.02 for freeways also applies to expressways.

58-4.04 Protective Fencing on Highway Overpasses

58-4.04(a) General

Protective fencing is generally provided wherever there is a potential hazard to highway users resulting from objects being dropped or thrown from overhead crossings, where there is a need to protect pedestrians who cross on the overpass, or where a bikeway is carried across the structure. This fencing is categorized as vertical pedestrian railing, curved bridge fence railing for pedestrians, and bicycle railings. The protective fencing should satisfy the aesthetic consideration of the structure and should be designed in conformance with the latest Department standards. See Part 510 of the *Illinois Administrative Code* for additional guidance. See the *Bridge Manual* for detailed drawings on the different types of protective fencing located on structures and to the typical sections shown in Figures 39-5.L and 39-5.M.

58-4.04(b) Evaluation of Need

The districts will be responsible for determining the need of vertical pedestrian railings or curved bridge fence railings. The vertical railing is desirable in urban areas where there is considerable pedestrian traffic on the bridge. The curved bridge fence railing may also be used in urban areas with considerable pedestrian traffic and where there are reported incidents of objects being throw or dropped from an overpass or there is the high potential of such events occurring. If fencing is required, the cost apportionment and maintenance requirement will be as discussed in Section 5-5.02(j).

58-4.04(c) Pedestrian Bridges

Provide protective fencing on all new pedestrian bridges. The cost apportionment will be the same as for the pedestrian crossing itself. The need for protective fencing on existing pedestrian bridges will be determined on case-by-case basis using the guidance discussed in Section 58-4.04(b).

58-4.05 Fencing or Safety Devices on Top of Retaining Walls

The purpose of a fence or safety device is to alert pedestrians, bicyclists, and/or motorists of a difference in elevation to prevent injury from a fall or vehicular crash. Consider installing a fence or safety device at the top of any wall that is over 1 ft (300 mm) tall if the top of the wall is closer than 2 ft (600 mm) to a sidewalk, trail, parking lot, public common area, or stairway landing. Walls located further away from human or vehicular activity may be higher before a fence is considered necessary. Regardless of the height of the wall, provide a fence or safety device if any activity (e.g., driving, walking, riding a bike, running, or other playground type activities) could result in harm or damage by someone inadvertently going over the wall. A fence or safety device is required when the difference in grade level on either side of the wall is in excess of 4 ft

(1.2 m) tall. Consider aesthetics of any fence, especially in urban areas, where the wall and barrier is located adjacent to private property.

58-5 MAILBOX TURNOUTS

Mailboxes and newspaper tubes served by carriers in vehicles may constitute a safety hazard, depending upon the placement of the mailbox and the width of the turnout. Therefore, the designer should make every reasonable effort to replace all non-conforming mailboxes and turnouts with designs that meet the criteria in the IDOT Maintenance Policy 3-100 "Placement of Newspaper Boxes," IDOT Maintenance Policy 3-200 "Construction and Maintenance of Mailbox Turnouts," and Chapter 11 of the AASHTO *Roadside Design Guide*. Mailbox turnouts must be addressed on reconstruction and 3R projects. Where shoulder widths permit on 3P and SMART projects, the designer should address mailbox turnouts. Coordination with the local postmaster and property owner is required for all changes of mailbox locations.

58-5.01 Location

Mailbox turnouts should be placed for maximum convenience to the patron, consistent with safety considerations for highway traffic, the carrier, and the patron. When determining the location of mailboxes, consider the following:

1. Intersections. Placing a mail stop near an intersection will have an effect on the operation of the intersection (e.g., reduction of intersection sight distance, blocked lanes). The nature and magnitude of this impact depends on traffic speeds, volumes on each of the intersecting roadways, the number of mailboxes at the stop, type of traffic control, how the stop is located relative to the traffic control, and the distance the stop is located from the intersection. Figure 58-5.A provides the recommended minimum clearance distances to mailbox stops near intersections. On State highways, many of the above potential problems are alleviated by the use of mailbox turnouts. Where feasible, locate all new turnout installations on the far-right side of an intersection with a public road. However, in some cases the designer may determine that it is preferable to locate the turnout on the near-side of an intersection.
2. Near-Side/Far-Side at Driveways. On rural two-lane highways where a single mailbox installation is required, the near side turnout is preferable because this design allows the postal patron to pull up to the mailbox and then to turn into the driveway without backing up. If there is a need for multiple mailbox installations at one location, the far-side turnout is preferable because all postal patrons except for one can pull into the turnout and then drive out and proceed to their homes. See Figure 58-5.B.
3. Newspaper Boxes. Newspaper boxes are only permitted at mailbox turnouts. Where practical, the newspaper box should be erected on the same post as the mailbox.

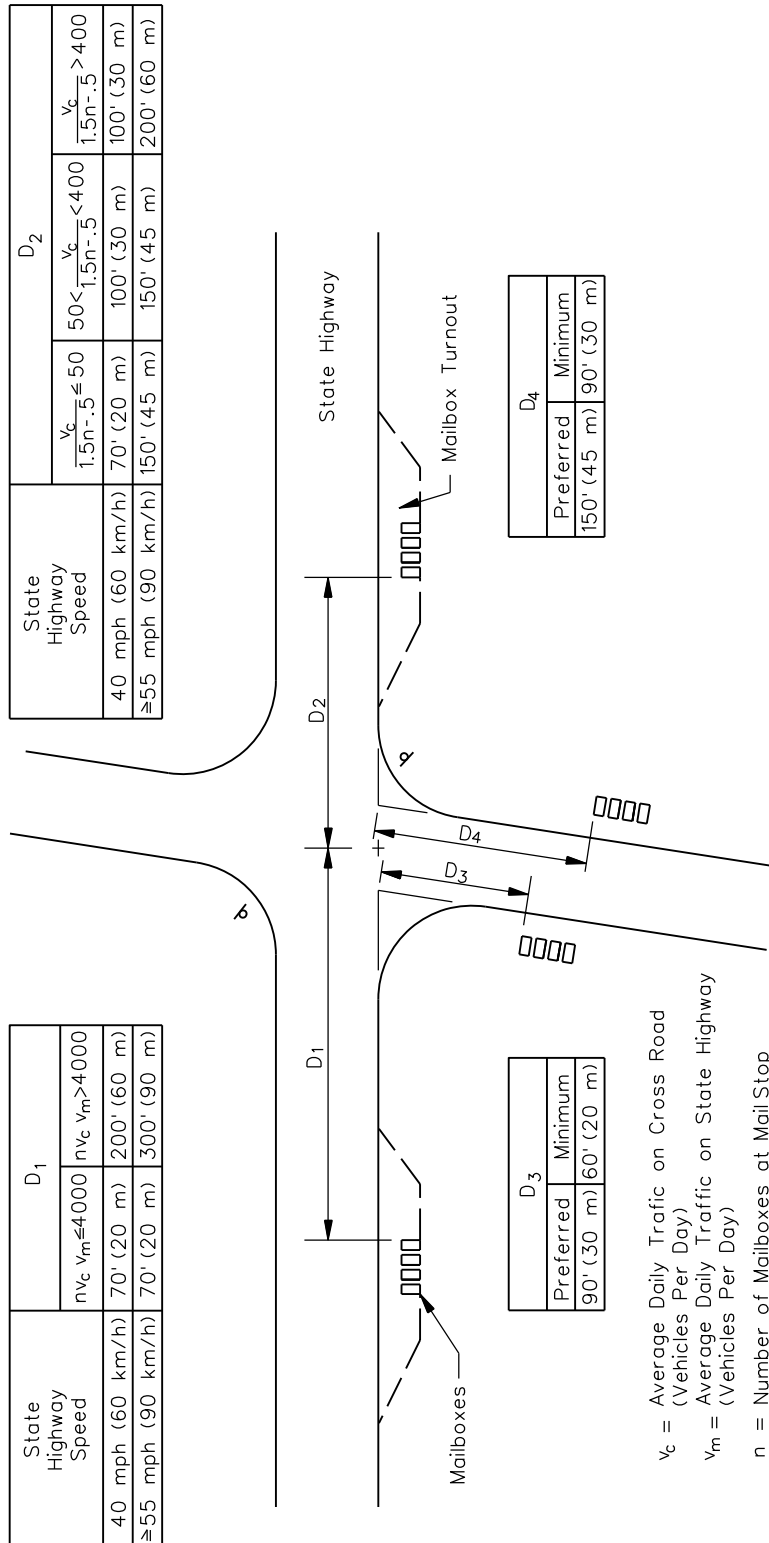

v_c = Average Daily Traffic on Cross Road (Vehicles Per Day)
 v_m = Average Daily Traffic on State Highway (Vehicles Per Day)
 n = Number of Mailboxes at Mail Stop

RECOMMENDED MINIMUM CLEARANCE DISTANCES TO MAILBOX STOPS NEAR INTERSECTIONS

Figure 58-5.A

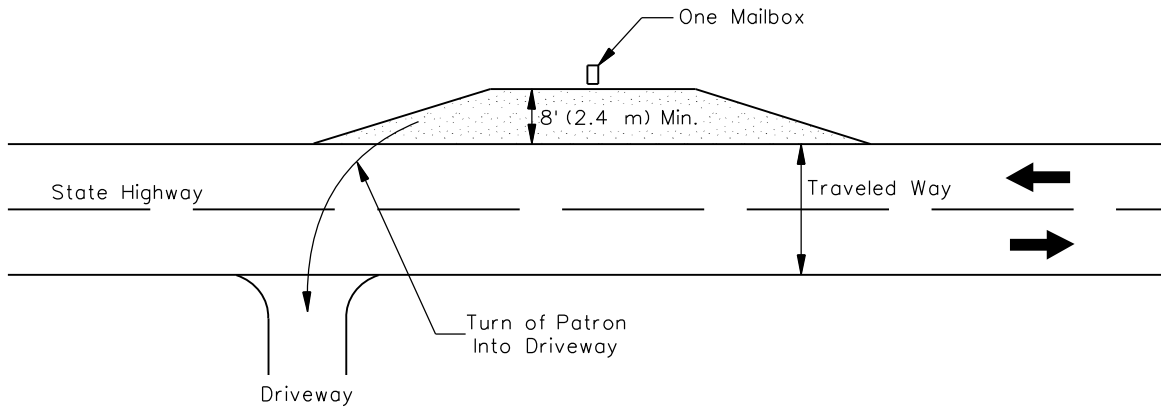

TURNOUT ON OPPOSITE SIDE OF HIGHWAY

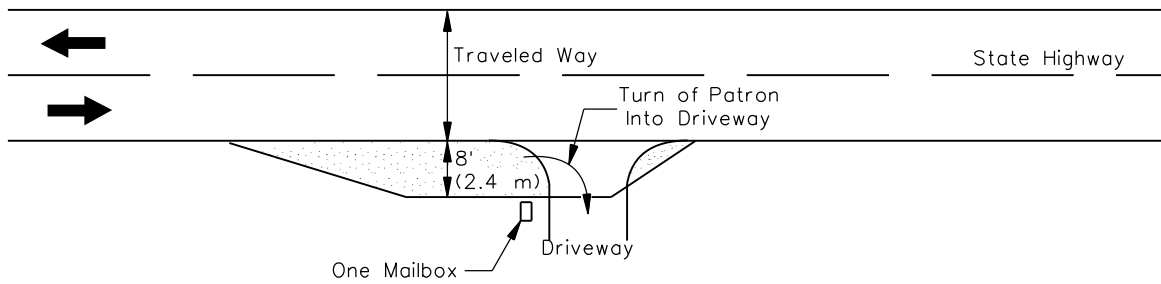

TURNOUT ON NEARSIDE OF DRIVEWAY WITH SINGLE MAILBOX

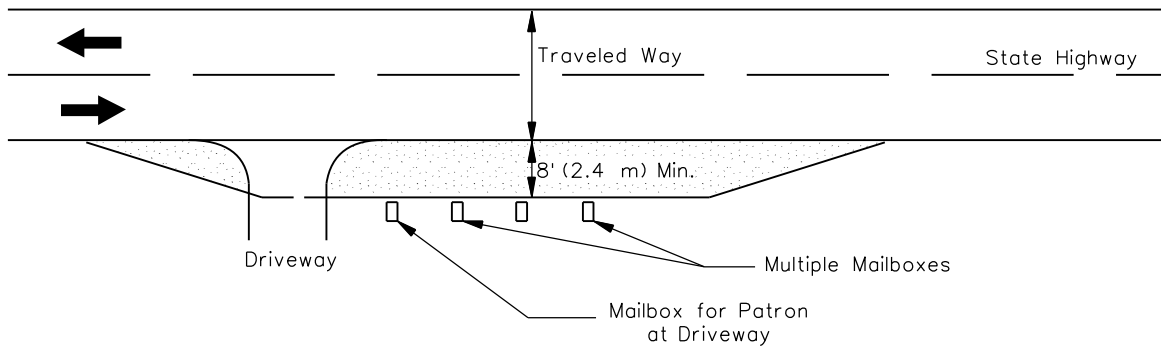

TURNOUT ON FAR SIDE OF DRIVEWAY WITH MULTIPLE MAILBOXES

MAILBOX TURNOUTS AND DRIVEWAYS

Figure 58-5.B

4. Postal Patrons. When determining the location of mailboxes, try to minimize the walking distance to the mailbox site for the patron. It is undesirable to require pedestrians to travel along the shoulder. However, this may be the preferred solution for distances up to 200 ft (60 m) when compared to other alternatives (e.g., constructing a turnout in a deep cut, placing a mailbox turnout just beyond a sharp crest vertical curve (poor sight distance), constructing two or more closely spaced turnouts).
5. Right or Left Side. Only place boxes on the right-hand side of the highway in the direction of travel of the carrier, except on one-way streets where they may be placed on the left-hand side; see Figure 58-5.B.
6. Guardrail. Where a mailbox is installed in the vicinity of an existing guardrail and where practical, place the mailbox support behind the guardrail.
7. High-Speed/High-Volume Facilities. On expressways or other high-speed multilane highways in rural areas, mail delivery usually is accomplished by the mail carrier using the 10 ft (3.0 m) wide paved shoulders for deceleration and as a mailbox turnout area. Where the local postmaster only will agree to deliver mail in one direction and a postal patron is located on the opposite side of the median, it may be necessary to provide a walkway through the median. This is highly undesirable and only should be used as a last resort. Instead, encourage the postal patron to pick up his/her mail at the post office.

As an option to shoulder mail delivery along the route, it may be possible to set up post office box delivery only. However, this change in mail delivery must be agreed to by the postal patrons and the local postmaster.

In some situations, a number of closely spaced houses may have access to a frontage road or service drive rather than direct access to the expressway. In this case, locate the mailboxes on the frontage road or service drive.

8. Suburban/Urban Areas. A potential problem frequently occurs on State highways where a roadway section with shoulder originally existed and where the roadway is reconstructed to a curb and gutter cross section. Previously, the mail carrier would have delivered mail from a vehicle by driving along the shoulder. With the reconstruction to a curb and gutter section, the mail would now have to be delivered by driving on the pavement adjacent to the curb and gutter. Under certain conditions, some mail carriers feel that mail delivery along a curb and gutter roadway has the potential to be hazardous. The factors which could contribute to a potential problem along the street are high-operating speeds, the number of through and turning lanes, and the amount of congestion due to traffic volumes. To alleviate the potential for mail delivery problems where a curb and gutter cross section is proposed, the district should work closely with local postmaster during the development of the project. In many cases, after coordination with a postmaster is completed, Department personnel will determine that the potential for mail delivery problems is minor and no special design features are needed. However, where the potential for mail delivery problems is determined to be

significant, it may be possible to modify rural type delivery on streets with curb and gutter by considering the following:

- a. Grouping. Where there are a number of closely spaced houses located along a State highway, it may be desirable to group two, four, or six mailboxes at one location. Due to the possibility of spearing of windshields by the horizontal support, it is desirable to individually mount each mailbox on a separate support. However, it may be acceptable to mount multiple mailboxes on one support if it meets the criteria in Chapter 11 of the AASHTO *Roadside Design*. Figures 58-5.C and 58-5.D illustrate possible placement for groups of mailboxes along urban routes.
 - b. Neighborhood Delivery and Collection Box Unit (NDCBU). Relocate all mailboxes along the block around the corner on a side street by using a NDCBU. However, it should be noted that postal patrons usually do not like this solution in older established neighborhoods.
 - c. Park and Loop Routes. Request the mail carrier to park his/her vehicle on a side street, walk the block, and return to the vehicle.
 - d. Paved Shoulder. Provide a continuous 6 ft (1.8 m) paved shoulder with curb and gutter located behind the shoulder. This alternative is expensive and right-of-way may not be available in many cases. However, this design allows for mail carriers, garbage trucks, and delivery trucks.
9. Problems. Where a satisfactory mail delivery solution cannot be reached between all parties involved, contact the Delivery Programs Support Analysts at one of the US Postal Services' district offices at the following locations:
- For northern Illinois, contact the postal official at (630) 260-5260.
 - For central Illinois, contact the postal official at (708) 563-7360.
 - For southern Illinois, contact the Midwest Area Office in St. Louis at (314) 692-5426.

58-5.02 Design Features

58-5.02(a) Typical Designs

The *Highway Standards* provide the geometric design criteria for rural mailbox turnouts. The designer should also consider the following:

1. Stopping Sight Distance. Ensure that there is sufficient stopping sight distance in advance of the mailbox turnout.

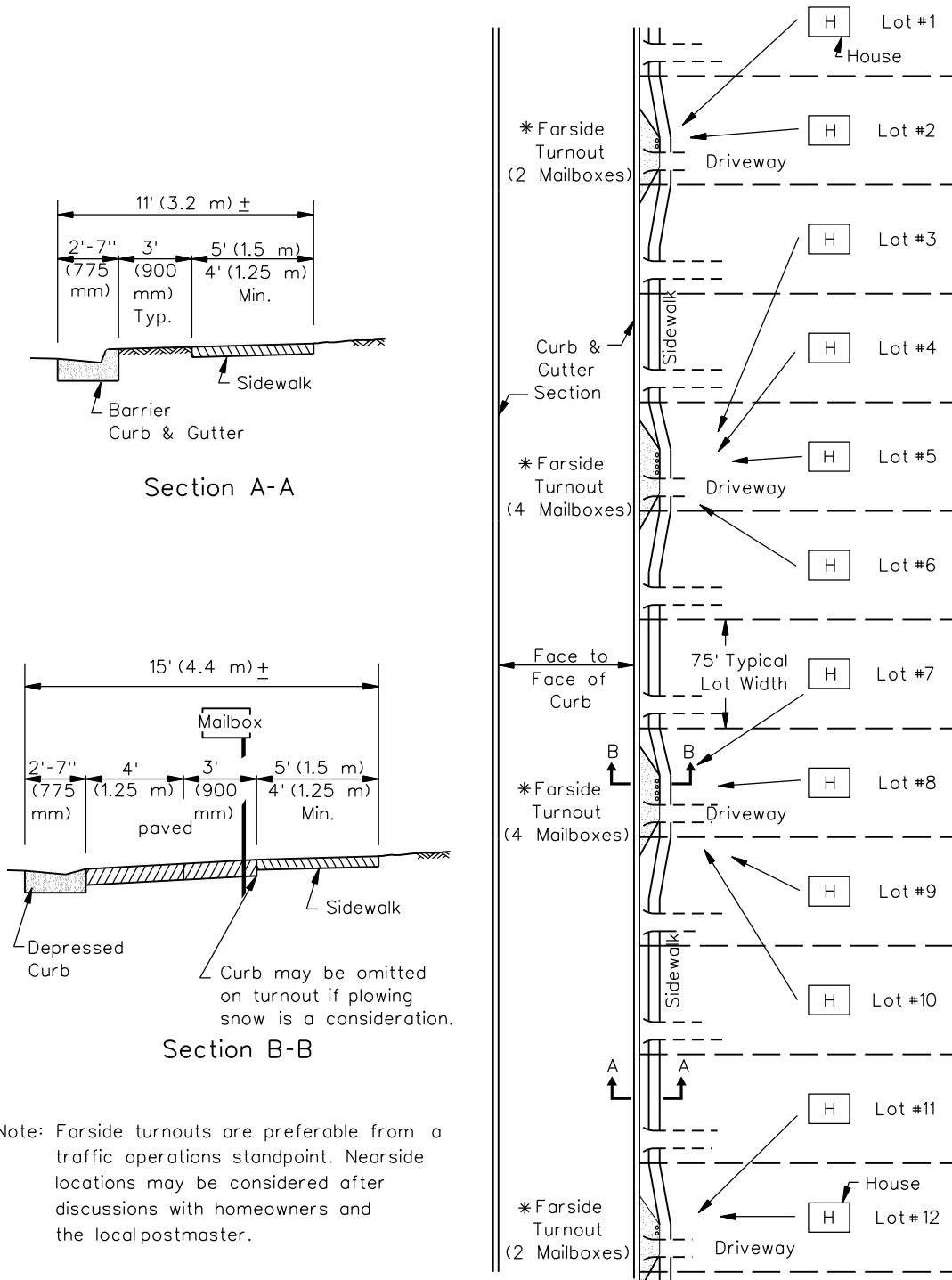

**URBAN MAILBOX TURNOUTS
(Two or Four Mailboxes Grouped Together)**

Figure 58-5.C

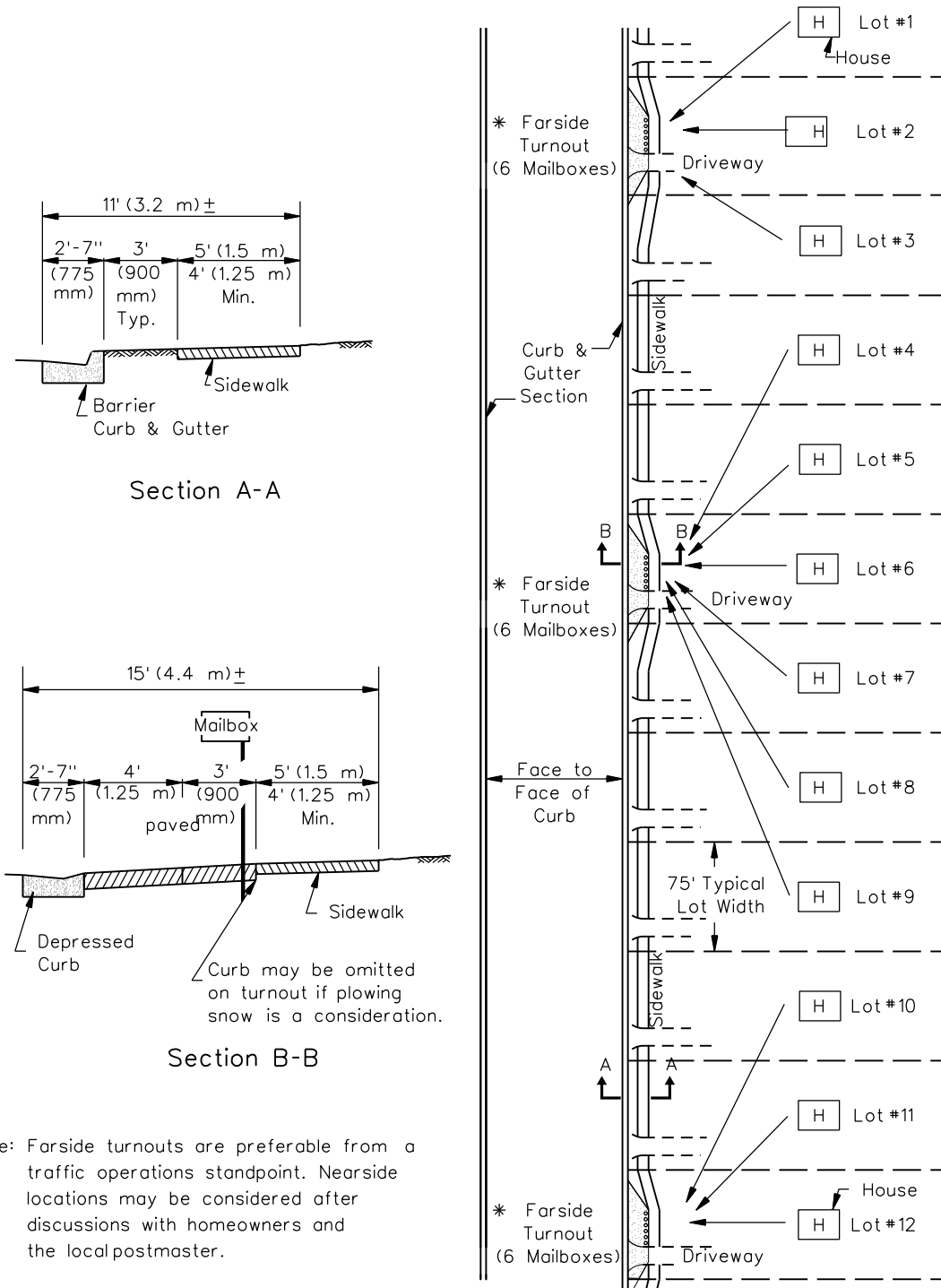

* Note: Farside turnouts are preferable from a traffic operations standpoint. Nearside locations may be considered after discussions with homeowners and the local postmaster.

**URBAN MAILBOX TURNOUTS
(Six Mailboxes Grouped Together)**

Figure 58-5.D

2. Width. To ensure stopped vehicles are outside of the traveled way, mailbox turnouts should be at least 8 ft (2.4 m) wide.
3. Narrow Shoulders. Widening and/or resurfacing of highways with limited right-of-way may result in shoulder widths which are too narrow for mailbox turnouts (i.e., less than 8 ft (2.4 m)). In these cases, it will be necessary to widen out the shoulder at the mailbox location to provide the minimum width and, in some cases, installing a sufficient length of pipe culvert to provide for roadside drainage.
4. Surface. Provide an all-weather surface at the turnout. The minimum design should be 6 in (150 mm) of aggregate or a combination of aggregate and a bituminous surface.
5. Heights. Mailbox heights are usually located so that the bottom of the box is 3 ft (1.0 m) to 4 ft (1.2 m) above the mail stop surface.
6. Mailbox Supports and Attachment Design. For guidance on mailbox posts, supports, and attachments, see the AASHTO *Roadside Design Guide*.
7. Multiple Mailboxes. To reduce the possibility of ramping, multiple mailboxes supports should be separated by a distance at least equal to three-fourths of their height above ground. Due to the number of vehicles using the turnout, desirably the surface should be bituminous. See 58-5.01 for restrictions on multiple mailboxes in a turnout.
8. Neighborhood Delivery and Collection Box Units (NDCBU). NDCBU is a cluster of 8 to 16 locked boxes mounted on a pedestal or within a framework. These clusters can weigh between 100 lbs to 200 lbs (45 kg to 90 kg) and may be a roadside hazard. Consequently, they should be located outside the clear zone in rural areas and preferably on a side street in urban areas. Normally, NDCBU are located in trailer parks, apartment complexes, and new residential subdivisions.

58-5.02(b) Special Designs

Due to the multitude of different conditions, the standard mailbox turnout designs may not always be practical. This is especially true in urban and suburban areas. Therefore, where special agreements have been reached with a local postmaster and where special designs will be needed, provide these details in the Phase I report. These commitments are then carried forward into the contract plans, plan notes, and special provisions.

If during the preparation of the plans it is determined that temporary locations will be required for mail delivery during construction, provide the necessary details in the plans and special provisions. Also, if it is determined that an existing mailbox support which has temporarily been moved is potentially hazardous to traffic, it should be replaced with a suitable support.

58-5.03 Mailbox Supports

During the preparation of the Phase I report, the district is required to address the problem of hazardous mailbox supports. Removal and replacement of mailboxes can be a sensitive issue and should be reviewed with the local postal authorities and the postal patron. The process to determine and achieve compliance on this issue consists of the following:

1. Survey. Conduct an on-site survey to determine whether there are any hazardous mailbox supports within the clear zone of the project. Document these locations in the Phase I report. If there are no hazardous supports on the project, note this in the Phase I report.
2. Notification by Department. If a mailbox box support is determined to be hazardous, the person conducting the field check is required to notify the postal patron. This can be accomplished either through the normal mail service or by placing a postage stamped envelope with a completed form letter enclosed into the patron's mailbox. A sample form letter is shown in Figure 58-5.E and discusses the following issues:

- potential adverse safety effects,
- appropriate safety design,
- potential personal liability, and
- IDOT's request to change the support to an acceptable design.

Note that the Department contacts postal patrons to remove or replace the support only when a highway is proposed for improvements.

3. Documentation. If an answer is received from the postal patrol, document the following in the project files for Phase II design:
 - the owner's decision to change to a safe mailbox support; or
 - if the owner is undecided, urge the owner to strongly consider a safe support and document all phone conversations or meetings and the results.
4. Notification by Postmaster. If no response is received from a postal patron who has a hazardous mailbox support or if the owner indicates that he/she does not wish to change the support, the district may contact the local postmaster and ask for the postmaster's help in getting the mailbox support removed. If the local postmaster is agreeable, he/she has the authority to notify the patron in writing of the safety hazard of an existing support. Postal regulations require that box supports must bend or break away when struck by a vehicle and that such supports are now readily available for purchase. The local postmaster can give the owner 30 days notice, and if compliance is not achieved, the postmaster has the authority to suspend mail delivery to the box.
5. Phase II Field Reviews. If a hazardous mailbox support is constructed or discovered after design approval, use the above procedures and add the appropriate documentation to the files and reports.

6. Documentation for Construction Personnel. Provide the resident engineer with the correct information on each property owner who has a hazardous mailbox support and what the owner has decided concerning the mailbox support. Also, see Section 58-5.02.

Date _____

Route _____
Marked Illinois Route _____
Section __________
CountyDescription of Mailbox Support _____
_____TO: _____

Dear _____:

It is the intent of the Illinois Department of Transportation to make improvements on the above-described route in the near future. A part of these improvements includes protecting the driving public from roadside hazards. A recent survey of mailbox supports within this project indicates that your mailbox support as described above is a potential hazard to the traveling public and should be changed to meet certain safety requirements.

Each year during Mailbox Improvement Week, the United States Postal Service provides you a pamphlet describing ways to aid the Postal Service in the delivery of your mail. The following is a paragraph, taken from a recent pamphlet, describing the kinds of supports that should be avoided because they can cause serious vehicular damage and personal injury.

“Reports have been received that some mailbox supports are so massive that they are damaging the vehicles and causing serious injuries to people who accidentally strike them. The use of heavy metal posts, concrete posts, and miscellaneous items of farm equipment, such as milk cans filled with concrete, should be avoided. The ideal support is an assembly which, if struck, will bend or fall away from the striking vehicle instead of severely damaging the vehicle and injuring its occupants.”

SAMPLE HAZARDOUS MAILBOX SUPPORT LETTER**Figure 58-5.E**

Because your mailbox support is private property, we do not intend to remove or change it to a safer type. However, in the interest of public safety, and to avoid any potential liability if struck by a vehicle, we are requesting that you consider changing the support to a safer type.

Because there are a number of different, safe designs from which to choose, we will be glad to help you select one that you would prefer. At the bottom of this letter, there is a name and telephone number which you can call (collect if you wish) to receive more information about the installation of a safety mailbox support.

If you prefer, you may also ask that someone visit your residence at an agreeable time, during Department working hours, to further explain the safety problems and assist you in selecting an appropriate, safe support. You may arrange this by means of the previously mentioned telephone number or by placing your name and telephone number in the space provided at the bottom on this letter and returning it in the pre-addressed, stamped envelope enclosed for your convenience.

Thank you for your cooperation. We are looking forward to hearing from you so that, together, we can improve highway safety.

Very truly yours,

| _____
Regional Engineer

P.S. For more information, please call:

_____ at _____
Name Telephone #

OR

I request that a Department representative call:

_____ at _____
Name Telephone #

SAMPLE HAZARDOUS MAILBOX SUPPORT LETTER

Figure 58-5.E
(Continued)

58-6 RECREATIONAL ROADS

Design criteria for recreational roads are applicable to roads in State parks, recreational areas, national forests, and scenic drives. The objective for this type of facility is to provide a safe highway and still retain the aesthetic, ecological, environmental, and cultural amenities of the area.

In the design of recreational roads, consider the following:

1. Design Criteria. For design guidance, see the "Recreational Roads" section in the *AASHTO A Policy on Geometric Design of Highways and Streets*. Strict adherence to highway criteria for these types of roads may be inappropriate and unwarranted. Design speeds are usually low and driver expectancy is such that the reduction of criteria does not produce serious safety concerns. Therefore, the designer must use engineering judgment to ensure that the criteria fit the terrain and expected usage of the highway.
2. Design Vehicle. Depending on the nature of the recreational areas, the most common design vehicle will be a motor home with a boat trailer. Where garbage pickup or other maintenance vehicles are required, an SU may be the appropriate design vehicle. In some situations, only a passenger car may be appropriate. The designer must use engineering judgment to determine the appropriate design vehicle. Use the selected design vehicle to determine lane widths, vertical clearances, intersection designs, etc.

58-7 SEALING OF ABANDONED WATER WELLS

Abandoned water wells located on highway project right-of-way must be properly sealed by a licensed well driller in accordance with the requirements of the Illinois Water Well Construction Code (77 Ill. Adm. Code 920.120 and 415 ILCS 30). When abandoned water wells are identified on proposed project right-of-way during Phase I or Phase II, appropriate provisions shall be included in the contract plans to ensure compliance with the applicable well sealing and notification requirements of the Water Well Construction Code. In addition, any information that the District has available concerning the abandoned well (e.g., location, depth, diameter, type, liner material, etc.) also shall be included in the plans.

58-8 SURVEY MARKERS AND MONUMENTS

58-8.01 Right-of-way Markers

Right-of-way markers are used to delineate the extent of State highway right-of-way. Construction details for right-of-way markers are illustrated in the *Highway Standards*.

Place right-of-way markers at the following locations:

- opposite points of curvature and tangency and opposite the midpoint of curves;
- along tangents so that two markers are always intervisible;
- at each corner of all offsets; and
- at all intersecting roads, except for streets in subdivisions outside of corporate limits.

Indicate the location of all right-of-way markers on the plans. Set the back of the marker flush with the right-of-way line.

Right-of-way markers may be omitted along freeways or controlled access highways where access control fencing is constructed on the right-of-way line. The fence line should be coincident with the right-of-way line (i.e., the back of the posts should be tangent to the right-of-way line). However, use markers for areas where the right-of-way line deviates from the fencing (e.g., grade separations, frontage roads) in compliance with the above requirements.

Do not place markers at the intersections of the right-of-way line with property lines in rural areas except for compliance with the above requirements. The intention of the markers is to delineate right-of-way lines and are not to be construed as indicating the dividing line between adjacent property owners.

58-8.02 Permanent Survey Markers

Permanent survey markers are used to delineate the highway centerline. Construction details for permanent survey markers are illustrated in the *Highway Standards*.

Place markers at the PT's and PC's of all horizontal curves and space them along tangents so that two markers are always intervisible. Indicate the location of all markers on the plans.

For two-lane highways, place the Type I markers on the centerline in the pavement. When these highways are resurfaced, the marker should be raised to be flush with the new surface or referenced by means of permanent ties as discussed in Section 58-8.03.

On divided highways, place Type II markers, either precast or site constructed, in the median so that the plaque is flush with the median surface. If the horizontal alignment of the opposing roadways is not concentric, reference the respective roadway centerlines to the survey centerline. The Type II marker may also be used as a permanent benchmark.

58-8.03 Permanent Survey Ties

Permanent survey ties should be used in place of survey markers on highways having bituminous surface treatments and may be used at the option of the Regional Engineer on highways having bituminous concrete surface courses.

The permanent ties must consist of a metal rod or pin embedded in concrete within the highway right-of-way. At least four permanent ties must be provided for each survey point and must be located so that arcs struck from the ties will result in a precise point of intersection. Construction details for permanent survey ties are illustrated in Figure 58-8.A.

58-8.04 Land Survey Monuments

Public Act 79-649 requires that monument records of US public land survey monuments used as control corners of a survey be filed with the Recorder of Deeds or Registrar of Titles in the county of the survey. Procedures and instructions for the implementation of this *Act* are contained in the *Land Acquisition Policies and Procedures Manual*.

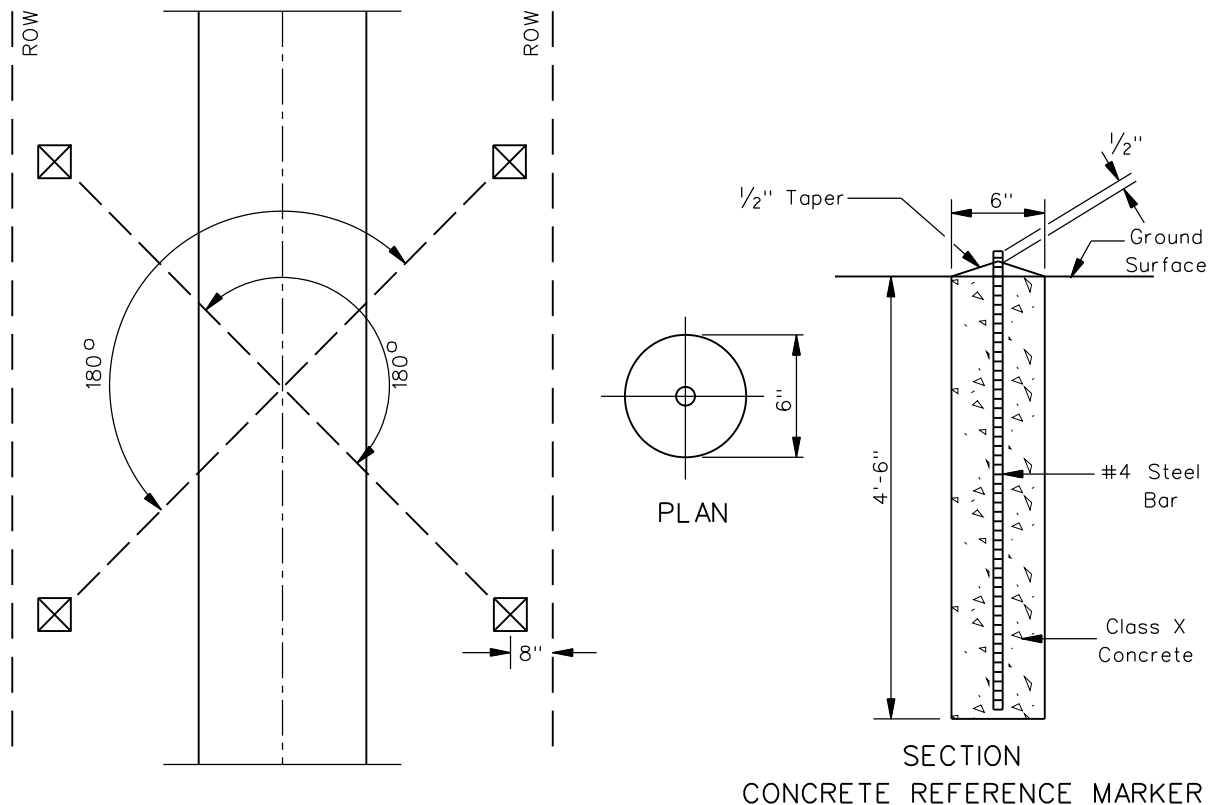

PERMANENT SURVEY TIES

Figure 58-8.A

The provisions of this *Act* also apply to Chapter 605 of the *Illinois Compiled Statutes* (ILCS), which pertains to the preservation of US public monuments that are subject to disturbance by the construction of a highway.

If it is determined during the design stage of a project that a US public land survey monument will be affected by the construction operations, the designer will prepare a Special Provision for inclusion into the contract providing for the preservation of the monument. Clearly indicate in the Special Provision the placement of reference monuments for the location of land survey monuments lowered below the finished grade. The Special Provision should clearly state that the setting of reference monuments, lowering of US public land survey monuments, measuring of distances and angles, and the preparation of the monument record document must be done by or under the supervision of either a contractor-provided or district-provided Illinois Professional Land Surveyor. It is also required that the monument records be filed in accordance with Chapter 765 ILCS 220/7.

Proper methods of referencing US public land survey monuments are discussed in the *Land Acquisition Manual*. Monuments referenced as indicated in the *Land Acquisition Manual* need not be placed or marked in the surface of the pavement but must be covered after the monument has been lowered to a level of a minimum of 12 in (300 mm) below the finished grade. Direct access to monuments under the pavement is not necessary and the installation of monument boxes is not required.

58-9 REFERENCES

1. *Accessibility Guidelines for Building and Facilities*, US Architectural and Transportation Barriers Compliance Board, 1991, 1994, 2004.
2. FHWA-IP-84-6, *Guidelines for Making Pedestrian Crossing Structures Accessible*, August, 1984.
3. FHWA-RD-84/082, *Warrants for Pedestrian Over and Underpasses*, 1984.
4. *A Policy on Geometric Design of Highways and Streets*, AASHTO, 2004.
5. *Guide for the Design of Park-and-Ride Facilities*, AASHTO, 2004.
6. *Traffic Engineering Handbook*, Institute of Transportation Engineers, 2009.
7. *The Location and Design of Bus Transfer Facilities*, Institute of Transportation Engineers, 1992.
8. *Guidelines for the Location and Design of Bus Stops*, TCRP Report 19, Transportation Research Board, 1996.
9. *Highway Standards*, IDOT.
10. *Standard Specifications for Road and Bridge Construction*, IDOT.
11. *Roadside Design Guide*, AASHTO, 2006.
12. *Land Acquisition Policies and Procedures Manual*, IDOT.

