

Chapter Fifty-five

WORK ZONE TRAFFIC CONTROL

BUREAU OF DESIGN AND ENVIRONMENT MANUAL

Chapter Fifty-five
WORK ZONE TRAFFIC CONTROL

Table of Contents

<u>Section</u>	<u>Page</u>
55-1 PLAN DEVELOPMENT	55-1.2
55-1.01 Transportation Management Plan	55-1.2
55-1.02 Transportation Management Plan Content.....	55-1.3
55-2 DESIGN CONSIDERATIONS	55-2.1
55-2.01 Constructability	55-2.1
55-2.01(a) Worksite	55-2.1
55-2.01(b) Construction Design.....	55-2.2
55-2.01(c) Economic/Business.....	55-2.2
55-2.01(d) Pedestrians/Bicyclists	55-2.3
55-2.02 Geometrics and Work Zone Design Speed	55-2.3
55-2.03 Lane/Shoulder Widths	55-2.4
55-2.04 Drop-Off Exposure.....	55-2.5
55-2.05 Transition Taper Rates	55-2.5
55-2.06 Sight Distance	55-2.5
55-2.07 Horizontal Curvature.....	55-2.13
55-2.08 Vertical Curvature.....	55-2.13
55-2.09 Cut and Fill Slopes	55-2.13
55-2.10 Pavement Design	55-2.16
55-2.11 Temporary Bridges	55-2.16
55-2.12 Crossovers to Remain in Place	55-2.17
55-3 DESIGN RECOMMENDATIONS	55-3.1
55-3.01 Lane/Shoulder Closures	55-3.1
55-3.02 Two-Way Traffic on Divided Highways.....	55-3.2
55-3.03 Runaround Detours	55-3.5
55-3.04 Local Route Detours.....	55-3.9
55-3.05 Stage Construction of Two-Lane, Two-Way Bridges.....	55-3.11
55-3.06 Stage Construction of Multilane Bridges	55-3.12
55-3.07 Reduced Traffic Control for Road Closed to Through Traffic	55-3.12
55-3.08 Interstate Work Zones	55-3.12
55-4 ROADSIDE SAFETY	55-4.1
55-4.01 Positive Protection.....	55-4.1
55-4.02 Appurtenance Types	55-4.3

Table of Contents
(Continued)

<u>Section</u>		<u>Page</u>
	55-4.02(a) Guardrail	55-4.3
	55-4.02(b) Temporary Traffic Barrier	55-4.3
	55-4.02(c) End Treatments	55-4.5
	55-4.02(d) Glare Screens	55-4.5
55-4.03	Design/Layout.....	55-4.6
55-5	WORK ZONE TRAFFIC CONTROL DEVICES.....	55-5.1
55-5.01	Highway Signs.....	55-5.1
	55-5.01(a) General	55-5.1
	55-5.01(b) Speed Limit Signing	55-5.1
	55-5.01(c) Guide Signs	55-5.1
	55-5.01(d) Portable Changeable Message Signs.....	55-5.2
	55-5.01(e) Arrow Boards	55-5.3
55-5.02	Channelization Devices	55-5.3
55-5.03	Pavement Markings.....	55-5.4
	55-5.03(a) Types	55-5.4
	55-5.03(b) Application	55-5.5
55-5.04	Traffic Signals.....	55-5.5
	55-5.04(a) Location	55-5.5
	55-5.04(b) Application	55-5.5
55-5.05	Highway Lighting and Nighttime Construction.....	55-5.6
	55-5.05(a) Types	55-5.6
	55-5.05(b) Warrants	55-5.6
	55-5.05(c) Lighting for Nighttime Construction	55-5.7
55-6	ENFORCEMENT	55-6.1
55-6.01	Implementation of Enforcement.....	55-6.1
	55-6.01(a) Hire-back of Police Patrols.....	55-6.1
	55-6.01(b) Photo Speed Enforcement.....	55-6.1
	55-6.01(c) Annual Highway Program	55-6.1
55-6.02	Fines.....	55-6.2
55-7	REFERENCES.....	55-7.1

Chapter Fifty-five

WORK ZONE TRAFFIC CONTROL

Highway construction often disrupts the normal flow of traffic and may pose safety hazards to motorists, bicyclists, pedestrians, and workers. Therefore, to mitigate potential operational and safety problems, IDOT requires that a Transportation Management Plan (TMP) be prepared for highway construction projects to consider work zone impacts upon the traveling public.

A Traffic Control Plan (TCP) is a plan to safely guide traffic through a construction project through the use of traffic control devices and project coordination. The TCP focuses on the mobility and protection of traffic within the construction zone. The TCP, part of the TMP, may range in scope from very detailed design plans and special provisions; to the incorporation of Special Provisions, Recurring Special Provisions, and/or Contract Special Provisions; or to merely referencing the *Highway Standards*, *Standard Specifications*, and detailing their use and location.

Chapter 55 provides the necessary information to develop a well-conceived TCP that minimizes the adverse effects of traffic disruption and hazards. This chapter draws heavily on the reader's knowledge of the work zone criteria in Part 6 of the *Illinois Manual on Uniform Traffic Control Devices* (ILMUTCD), *Highway Standards*, and *Standard Specifications*. Work zone traffic control practices and motorist driving patterns are constantly changing and these publications are kept as current as practical.

The key for effective traffic control is consistency. By providing traffic control consistently throughout the State, drivers will recognize the significance of the devices used and react accordingly. When problems or unique situations arise in the development of the traffic control plan, the designer should consult with the District Traffic Control Supervisor. This position is the district contact responsible for resolving unique work zone traffic control issues. Information also applicable to the maintenance and protection of traffic through work zones is included in the following chapters:

- Chapter 13 discusses IDOT's Work Zone Safety and Mobility Rule and provides guidelines for selecting the appropriate traffic control strategy and preparation of a Transportation Management Plan .
- Chapters 31, 32, 33, and 34 provide guidance on the geometric design elements that are also applicable to work zones.
- Chapter 38 provides guidelines on roadside safety.
- Chapter 57 provides guidance on permanent pavement markings, highway signing, and traffic signals.
- Chapter 58 provides guidance on highway lighting.

- Chapter 63 provides guidelines on the preparation of construction plans, including construction and traffic control sheets.
- Chapter 66 provides information and guidelines on the preparation of *Standard Specifications*, *Special Provisions*, *Recurring Special Provisions*, *Contract Special Provisions*, and *Highway Standards*.

55-1 PLAN DEVELOPMENT

55-1.01 Transportation Management Plan

Each Phase I report should contain a TMP that provides the preferred overall strategy for accommodating traffic during construction. The TMP should provide an initial, proposed strategy for addressing traffic control through a work zone (e.g., detour, runaround, crossovers). For many projects, the TMP will not only address the alternatives confined to the project site, but may also address the impact traffic will have on the entire corridor. The earlier in the design process potential traffic control problems are identified, the earlier solutions can be developed and incorporated into the overall project.

Chapter 13 provides guidance on the issues that should be considered during the preparation of the TMP. The goals that directly impact design and planning are:

1. Safety. When analyzing work zone safety measures, consider the following:
 - zero worker fatalities for traffic-related work zone crashes,
 - reduce the number of motorist fatalities in traffic-related work zone crashes by 10% each year with the eventual goal of eliminating all fatalities,
 - eliminate crashes and resulting fatalities and serious injuries caused by queuing, and
 - reduce the number of work zone crashes by 5% from each prior year.
2. Mobility. Consider the following:
 - delays caused by work zones should not exceed more than 5 minutes per mile (3 minutes per km) of project length with a maximum of 30 minutes above the normal recurring traffic delay, and
 - queues caused by work zones should be no more than 1.5 miles (2.5 km) beyond pre-existing queues.

Even if the TMP has been fully developed in the Phase I report and has satisfied the goals, the designer should check to ensure the TMP is still applicable. This is especially true for projects that may have been several years in the development process. If the TMP needs to be modified, present the project at a coordination meeting. If the TMP is acceptable and satisfies

the delay and queuing goals, then the development of the final plans for Phase II can be prepared. If the goals are not met, then submit a “Request for Exception to Compliance” to the Bureau of Safety Engineering for further approval; see Chapter 13.

If the project is on a significant route and did not require a Phase I report, or if the TMP was not completely developed in Phase I, then a TMP should be developed in accordance with Chapter 13 to address safety and mobility goals.

If the project did not require a project report and the project is not on a significant route, it will be the designer’s responsibility to prepare a TMP in Phase II consistent with the requirements presented in this chapter and Chapter 13.

55-1.02 Transportation Management Plan Content

The TMP should include the preferred traffic control method for accommodating traffic during construction and the expected work zone impacts. Depending on whether a project is on a significant route or not, a TMP can have the following three components:

1. Traffic Control Plan (TCP). A TCP is a plan to safely guide traffic through a construction project through the use of traffic control devices and project coordination. The TCP focuses on the mobility and protection of traffic within the work zone.
2. Transportation Operations Plan (TOP). A TOP is a plan that consists of strategies that mitigate work zone impacts through the use of improved transportation operations and management of the transportation system.
3. Public Information Plan (PIP). A PIP is a plan that consists of strategies to inform those affected road users including the surrounding community of the expected impact of a project, of changing conditions, and available travel options.

A TCP is required on all IDOT highway projects. A TOP and PIP are required on projects designated as significant routes, but should be considered on all projects. See Chapter 13 for guidance on significant routes.

Figure 55-1.A illustrates the format and required opening paragraphs for the TCP that are placed in the special provisions. Include these paragraphs, or similar paragraphs, on every project.

Traffic Control Plan

Effective 1985 Revised 1/2/97

9-107T1-97

Traffic control shall be according to the applicable sections of the Standard Specifications for Road and Bridge Construction, the guidelines contained in the Illinois Manual on Uniform Traffic Control Devices for Streets and Highways, the Supplemental Specifications, these Special Provisions, and any special details and highway standards contained herein and in the plans.

Special attention is called to Articles 107.09 and 107.14 of the Standard Specifications for Road and Bridge Construction and the following traffic control related (1) Highway Standards; (2) Supplemental Specifications and Recurring Special Provisions; and (3) Other Special Provisions which are included in this contract:

1. Standards: *(List applicable traffic control standards)*
2. Supplemental Specifications and Recurring Special Provisions:
(List titles of applicable Recurring Specs which relate to traffic control)
3. Special Provisions: *(List titles of traffic control related special provisions)*

**SPECIAL PROVISIONS FOR CONSTRUCTION PROJECTS
(Sample Format)**

Figure 55-1.A

55-2 DESIGN CONSIDERATIONS

The objective of the traffic control plan (TCP) is to provide an implementation strategy that will minimize the adverse effects of traffic disruption on motorists, pedestrians, and bicyclists and provide a safe work area for workers. The following sections present design criteria that apply to temporary crossovers on divided highways, existing roadways through work zones, and detours specifically designed for construction projects (e.g., crossovers, runarounds). These criteria do not apply to detours over existing routes, which are presented in Section 55-3.04.

Consider the following engineering elements when developing the TCP:

1. Geometrics. The TCP should provide adequate facilities for drivers to maneuver safely through the construction area, day or night. The design should avoid frequent and abrupt changes in roadway geometrics (e.g., lane narrowing, lane drops, transitions that require rapid maneuvers). Section 55-2 presents the geometric design criteria applicable to work zones.
2. Roadside Safety. Motorist, pedestrian, bicyclist, and worker safety is a high priority element of any TCP and should be an integral part of each phase of the construction project (i.e., planning, design, and construction). Section 55-4 addresses the roadside safety issues typically encountered during construction.
3. Highway Capacity. The TCP should, where practical, provide the capacity necessary to maintain an acceptable level-of-service for the traveling public. This may require converting shoulders to travel lanes, eliminating on-street parking, constructing temporary lanes, limiting lane closures to hours when the capacity can be maintained, or expanding public transportation. Section 13-3.02(b) provides further information on highway capacity issues.
4. Special Traffic Control Devices. Special traffic control devices not included in the *Highway Standards* are included in the TCP to safely direct vehicles through or around the work zone. Coordinate the selection and location of these special traffic control devices with the Bureau of Safety Engineering and the Bureau of Operations. Section 55-5 provides guidance on the selection and location of traffic control devices in work zones.
5. Overhead Lighting. The designer should maintain existing overhead lighting and, on a case-by-case basis, consider the need for supplemental roadway lighting at potentially hazardous sites within the work area. Section 55-5.05 discusses the use of work zone lighting.

55-2.01 Constructability

55-2.01(a) **Worksite**

Evaluate the construction sequence of the proposed TCP to identify any safety, operational, or logistical problems and to facilitate the timely completion of the project. Special attention must

be focused on provisions for the contractor to access the work site, deliver and store materials, and worker parking. Consider a worksite delivery plan for complex projects (e.g., turnouts in temporary traffic barrier for delivery trucks to accelerate and decelerate safely into and out of the traffic flow).

Some of the elements that should be evaluated include:

- the maneuverability of traffic through the horizontal and vertical alignment during all construction phases;
- the separation of opposing traffic, workers, equipment, and other hazards;
- the work areas that will be used for equipment maneuverability and construction inspection;
- oversize and overweight load requirements for construction; and
- the access points to work and material storage sites.

55-2.01(b) Construction Design

Several construction options are available that may reduce construction time or modify the time of construction. These options allow flexibility in planning the work to allow the TMP to better meet safety and mobility goals. Consider the following:

- the use of special materials (e.g., quick-curing concrete that can support vehicular loads within hours after placement);
- the use of special designs (e.g., using precast box culverts instead of cast-in-place box culverts or bridges);
- special scheduling requirements that will reduce traffic disruptions (e.g., working at night and during off-peak hours);
- project phasing that will allow traffic to use the facility prior to project completion; and
- contractor cost incentives/disincentives for early/late completion of construction for facilities with a high ADT; see Section 66-2.04.

55-2.01(c) Economic/Business

Review the TCP to ensure that it does not restrict access to businesses during peak periods. Consider access for large trucks to businesses for deliveries or from manufacturers that generate high truck traffic. Review the discussion for a Public Information Plan in Section 13.4.

55-2.01(d) Pedestrians/Bicyclists

The safe accommodation of pedestrians/bicyclists through the work zone should be addressed early in project development. Whenever possible, work should be done in a manner that does not disrupt existing pedestrian/bicycle facilities; however when such disruption is necessary, the MUTCD requires alternate routes to be provided. Further, the alternate routes shall be detectable and shall include accessibility features consistent with the features present in the existing facility.

Consider the following guidelines when addressing pedestrian/bicycle accommodation through work zones:

1. **Separation.** Physically separate pedestrians/bicyclists and vehicles where practical.
2. **Construction.** Plan the construction so the disruption of pedestrian/bicycle facilities will occur in the shortest practical time or during non-peak times.
3. **Detours.** Pedestrian detours should be avoided since pedestrians rarely observe them and the cost of providing an accessible detour might outweigh the cost of maintaining the existing access route. When detours are used, they should be designed to minimize adverse travel and the number of pedestrian street crossings.
4. **Temporary Sidewalks.** Where temporary sidewalks are provided, consider the following:
 - a. **Width.** The width of temporary sidewalks should be equal to the existing sidewalk; however the minimum continuous clear width will be 4 ft (1.2 m). Wider sidewalks should be considered where there are high pedestrian volumes. For temporary sidewalks with clear widths less than 5 ft (1.5 m), a 5 ft x 5 ft (1.5 m x 1.5 m) passing space should be provided at least every 200 feet (60 m).
 - b. **Surface.** The surface of temporary sidewalks must be firm, stable and slip resistant. If the temporary sidewalk is to remain-in-place for more than four weeks, provide a 2 in (50 mm) Portland cement or asphalt surface. The material selection should be at the contractor's option. For temporary sidewalks to remain-in-place less than four weeks, a 3 in (75 mm) compacted aggregate surface may be provided.

55-2.02 Geometrics and Work Zone Design Speed

The TCP should provide adequate facilities for drivers to maneuver safely through the construction area, day or night. The design should avoid frequent and abrupt changes in roadway geometrics (e.g., lane narrowing, lane drops, transitions that require rapid maneuvers). The work zone design speed applies to the design of the geometric elements through the work zone. It does not apply to the regulatory speed limits that are used for posting the speed limit through the work zone and construction site.

When selecting the work zone design speed, consider the following factors:

1. Posted Speed Limit. The work zone design speed should reflect the following:

- the existing posted speed limit of the facility before construction begins,
- the anticipated posted speed limit through the work zone, and
- the posted speed limit of the facility immediately prior to the work zone.

The work zone design speed normally should not be more than 10 mph (15 km/h) below the posted speed limit prior to construction. Speed reductions greater than 10 mph (15 km/h) (e.g., 20 mph to drop an existing 65 mph speed limit to 45 mph) may be warranted by the complexity of the work zone; see the Bureau of Operations "Policy on Establishing and Posting Speed Limits on the State Highway System."

2. Urban/Rural. Work zone design speeds in rural areas should generally be higher than those in urban areas. This is consistent with the typically fewer constraints in rural areas (e.g., less development).

3. Terrain. Lower work zone design speeds may be applicable for rolling terrains. This is consistent with the typically higher construction costs as the terrain becomes more rugged.

4. Traffic Volumes. For some facilities, the work zone design speed may vary according to the traffic volumes (i.e., use higher design speeds as traffic volumes increase).

See the Bureau of Operations "Policy on Establishing and Posting Speed Limits on the State Highway System" for further guidance on regulatory and work zone speed limits.

55-2.03 Lane/Shoulder Widths

In general, avoid reductions in the roadway cross section width through the construction and work zones. However, this is often not practical given the constraints of the project. When determining lane and shoulder widths in work zones, consider the following guidelines:

1. Divided Highways. For freeways and other divided highways, desirably use 12 ft (3.6 m) wide lanes but as a minimum, maintain an 11 ft (3.3 m) lane width with 2 ft (600 mm) wide right and left shoulders. Under restrictive urban conditions, a 10 ft (3.0 m) lane width may be considered if an alternative detour route is provided for wide vehicles.

2. Undivided Highways. For undivided highways, maintain a minimum 10 ft (3.0 m) lane width and 1-ft (300-mm) wide shoulders.

3. Single-Lane Facilities. For single-lane roadways that are less than 14 ft (4.2 m) wide, evaluate the need for an alternative wide-load detour route. Ensure the wide-load detour is adequately marked in advance of the work zone.

4. Runarounds. Figure 55-3.C provides the minimum roadway widths for runarounds.

5. Temporary Crossovers. In addition to the above minimum criteria for lane widths, Section 55-3.02 presents the minimum lane widths for the crossover portion.
6. Options. In most cases, it will be more desirable to reduce the shoulder widths versus reducing the traveled way width.

55-2.04 Drop-Off Exposure

A drop-off is defined as an elevation difference between lanes or the edge of the traveled lane and shoulder as traversed by the wheel of a motor vehicle. Changes in elevation along highways present exposure to risk for highway users, especially vulnerable users (e.g., motorcyclists). Exposure can be limited by reducing speed, increasing lateral distance to the drop-off, providing a transition, or installing a barrier.

Figures 55-2.A and 55-2.B provide policy for designers in preparing project plans. Two conditions apply to all the figures:

- For local roads less than or equal to 400 ADT, barricades may be substituted for temporary traffic barrier based on engineering judgment.
- Spot locations for two lane, two way highways with continuous flagging or traffic signals may omit barrier for up to 96 hours.

55-2.05 Transition Taper Rates

Lane closures, lane width reductions, and lane shifts require the use of transition tapers to safely maneuver traffic around the encroaching restriction. These taper rates are shown in Figure 55-2.C. Figures 55-2.D and 55-2.E illustrate the minimum taper lengths for various taper applications in work zones (e.g., lane closures, lane shifts). The *Highway Standards* also present the minimum taper lengths for various taper applications in construction zones (e.g., lane closures, lane shifts). Use the design speed when selecting the appropriate taper rate.

55-2.06 Sight Distance

When considering sight distance in work zones, review the following:

1. Approaches. For the approach to the first physical indication of the work zone, the sight distance available to the motorist should be desirably based on the decision sight distance criteria provided in Section 31-3 and, at a minimum, on the stopping sight distance criteria provided in Section 31-3.
2. Construction Site. Through the construction site itself, ensure that at least the minimum stopping sight distance is available to the driver at all times.

3. Design Features. The location of many design features are often dictated by construction operations. Locate lane closures and transitions where the approaching driver has decision sight distance available to the lane closure.
4. Horizontal Curves. For horizontal curves in the work zone, check the horizontal clearance (i.e., the middle ordinate) of the horizontal curve using its radius and the minimum stopping sight distance for the work zone design speed; see Section 32-4.

Drop-off Location	Normal Posted Speed	Drop-off Height (x) and Type	Physical Treatment ⁽¹⁾⁽²⁾	Additional Requirements
Between Lanes	≥ 45 mph	≤ 1 in lift difference or ≤ 1 in vertical milled face	None	None
		1 in < x ≤ 2 in lift difference or 1 in < x ≤ 1.5 in vertical milled face	None	Uneven lane signs (2 mile spacing on Interstate & Expressway) (1 mile spacing on rural highway) (Spacing as per the TCP on urban sections)
		2 in < x ≤ 4 in lift difference	Notched longitudinal wedge ⁽⁴⁾	
		1.5 in < x ≤ 4 in vertical milled face	Temporary wedge or milled sloped edge min 1:3 ⁽⁴⁾	As per lane closure standard
		4 in < x ≤ 12 in ⁽³⁾	Lane closure using channelizing devices	
		> 12 in	Lane closure using temporary traffic barrier	
Between Lanes	< 45 mph	≤ 1 in lift difference or ≤ 1.5 in vertical milled face	None	None
		1 in < x ≤ 2.5 in lift difference	None	Uneven lane signs
		2.5 in < x ≤ 4 in lift difference	Notched longitudinal wedge ⁽⁴⁾	
		1.5 in < x ≤ 4 in vertical milled face	Temporary or milled sloped edge min of 1:3 ⁽⁴⁾	As per lane closure standard
		4 in < x ≤ 12 in ⁽³⁾	Lane closure using channelizing devices	
		> 12 in	Lane closure using temporary traffic barrier	

Notes:

- (1) Place channelizing devices and/or temporary barrier at the same level as the traveling lane.
- (2) Channelizing devices may be placed at the drop-off elevation to preserve lane width. Raise the reflective area and warning light (if required) to the required elevation above the traveling lane as per **Highway Standard 701901**.
- (3) Drop-off 4 in < x ≤ 12 in is permitted for less than 0.5 mile length of drop-off exposure in work zone or less than 48-hour closure time. Length and duration of drop-off in excess of limits require temporary traffic barrier. Adjacent work spaces that are essentially continuous in drop-off exposure should be considered as one work zone.
- (4) Or the same physical treatment and sign requirements as 4 in < x ≤ 12 in.

**CONDITION 1 — DROP-OFF BETWEEN TRAVELED LANES
(Excludes Pavement Patching) (US Customary)**

Figure 55-2.A

Drop-off Location	Normal Posted Speed	Drop-off Height (x) and Type	Physical Treatment ⁽¹⁾⁽²⁾	Additional Requirements
Between Lanes	≥ 45 mph	≤ 25 mm lift difference or ≤ 25 mm vertical milled face	None	None
		25 mm < x ≤ 50 mm lift difference or 25 mm < x ≤ 37 mm vertical milled face	None	Uneven lane signs (3.2 km spacing on Interstate & Expressway) (1.6 km spacing on rural highway) (Spacing as per the TCP on urban sections)
		50 mm < x ≤ 100 mm lift difference	Notched longitudinal wedge ⁽⁴⁾	
		37 mm < x ≤ 100 mm vertical milled face	Temporary wedge or milled sloped edge min 1:3 ⁽⁴⁾	As per lane closure standard
		100 mm < x ≤ 300 mm ⁽³⁾	Lane closure using channelizing devices	
		> 300 mm	Lane closure using temporary traffic barrier	
Between Lanes	< 45 mph	≤ 25 mm lift difference or ≤ 37 mm vertical milled face	None	None
		25 mm < x ≤ 67 mm lift difference	None	Uneven lane signs
		67 mm < x ≤ 100 mm lift difference	Notched longitudinal wedge ⁽⁴⁾	
		37 mm < x ≤ 100 mm vertical milled face	Temporary or milled sloped edge min of 1:3 ⁽⁴⁾	As per lane closure standard
		100 mm < x ≤ 300 mm ⁽³⁾	Lane closure using channelizing devices	
		> 300 mm	Lane closure using temporary traffic barrier	

Notes:

- (1) Place channelizing devices and/or temporary barrier at the same level as the traveling lane.
- (2) Channelizing devices may be placed at the drop-off elevation to preserve lane width. Raise the reflective area and warning light (if required) to the required elevation above the traveling lane as per **Highway Standard 701901**.
- (3) Drop-off 100 mm < x ≤ 300 mm is permitted for less than 800 m length of drop-off exposure in work zone or less than 48-hour closure time. Length and duration of drop-off in excess of limits require temporary traffic barrier. Adjacent work spaces that are essentially continuous in drop-off exposure should be considered as one work zone.
- (4) Or the same physical treatment and sign requirements as 100 mm < x ≤ 300 mm.

**CONDITION 1 — DROP-OFF BETWEEN TRAVELED LANES
(Excludes Pavement Patching) (Metric)**

Figure 55-2.A

Drop-off Location	Normal Posted Speed	Drop-off Height (x) and Type	Treatment Required
≤ 3 ft ⁽¹⁾⁽²⁾	all	≤ 1 in	None
		$1 \text{ in} < x \leq 3$ in	Low Shoulder signs (2 mile spacing)
	< 45 mph	$3 \text{ in} < x \leq 18$ in	Place channelizing devices at 50-ft spacing
	≥ 45 mph	$3 \text{ in} < x \leq 12$ in	Place channelizing devices at 100-ft spacing
	< 45 mph	$18 \text{ in} < x \leq 24$ in for < 0.5 mile or < 48 hours ⁽⁴⁾	Place channelizing devices at 50-ft spacing
	≥ 45 mph	$12 \text{ in} < x \leq 18$ in for < 0.5 mile or < 48 hours	Place channelizing devices at 100-ft spacing
	≥ 45 mph	$12 \text{ in} < x \leq 24$ in for > 0.5 mile or > 48 hours	Closure using temporary traffic barrier
	< 45 mph	$18 \text{ in} < x \leq 24$ in ⁽⁵⁾	Closure using temporary traffic barrier
	≥ 45 mph	$18 \text{ in} < x \leq 24$ in for < 0.5 mile or < 48 hours ⁽⁵⁾	Closure using temporary traffic barrier
all	> 24 in ⁽⁵⁾	Closure using temporary traffic barrier	
$3 \text{ ft} < x \leq 8$ ft ⁽³⁾	all	≤ 1 in	none
		$1 \text{ in} < x \leq 3$ in	Low Shoulder signs (2-mile spacing)
	< 45 mph	$3 \text{ in} < x \leq 24$ in ⁽⁴⁾	Place channelizing devices at 50-ft spacing
	≥ 45 mph	$3 \text{ in} < x \leq 24$ in	Place channelizing devices at 100-ft spacing
all	24 in ⁽⁵⁾	Closure using temporary traffic barrier	
> 8 ft to the work zone clear zone ⁽³⁾	< 45 mph	$12 \text{ in} < x \leq 24$ in ⁽⁴⁾	Place channelizing devices at 50-ft spacing
	≥ 45 mph	$12 \text{ in} < x \leq 24$ in	Place channelizing devices at 100-ft spacing
	all	> 24 in ⁽⁵⁾	Closure using temporary traffic barrier

Notes:

- (1) Place channelizing devices and/or temporary barrier at the same level as the traveling lane or shoulder profile.
- (2) Channelizing devices may be placed at the drop-off elevation to preserve lane width. Raise the reflective area and warning light (if required) to the elevation above the traveling lane or shoulder profile as per **Highway Standard 701901**.
- (3) Place channelizing devices or temporary barrier at same level as the side slope profile to be fully visible.
- (4) Length and duration may be exceeded for urban areas when engineering judgment indicates sight distance will be adversely affected by temporary barrier.
- (5) Temporary traffic barrier may be eliminated for stationary operations of less than 24 hours for multilane, and may be eliminated for stationary operations of less than 96 hours per stage for two lanes, based on engineering judgment.

CONDITION 2 — DROP-OFF BETWEEN TRAVEL LANE AND SHOULDER/EDGE OF PAVEMENT (US Customary)
Figure 55-2.B

Drop-off Location	Normal Posted Speed	Drop-off Height (x) and Type	Treatment Required
$\leq 900 \text{ mm}^{(1)(2)}$	all	$\leq 25 \text{ mm}$	None
		$25 \text{ mm} < x \leq 75 \text{ mm}$	Low Shoulder signs (3.2 km spacing)
	$< 45 \text{ mph}$	$75 \text{ mm} < x \leq 450 \text{ mm}$	Place channelizing devices at 15-m spacing
	$\geq 45 \text{ mph}$	$75 \text{ mm} < x \leq 300 \text{ mm}$	Place channelizing devices at 30-m spacing
	$< 45 \text{ mph}$	$450 \text{ mm} < x \leq 600 \text{ mm}$ for $< 800 \text{ m}$ or $< 48 \text{ hours}^{(4)}$	Place channelizing devices at 15-m spacing
	$\geq 45 \text{ mph}$	$300 \text{ mm} < x \leq 450 \text{ mm}$ for $< 800 \text{ m}$ or $< 48 \text{ hours}$	Place channelizing devices at 30-m spacing
	$\geq 45 \text{ mph}$	$300 \text{ mm} < x \leq 600 \text{ mm}$ for $> 800 \text{ m}$ or $> 48 \text{ hours}$	Closure using temporary traffic barrier
	$< 45 \text{ mph}$	$450 < x \leq 600 \text{ mm}^{(5)}$	Closure using temporary traffic barrier
	$\geq 45 \text{ mph}$	$450 \text{ mm} < x \leq 600 \text{ mm}$ for $< 800 \text{ m}$ or $< 48 \text{ hours}^{(5)}$	Closure using temporary traffic barrier
$900 \text{ mm} < x \leq 2.4 \text{ m}^{(3)}$	all	$\leq 25 \text{ mm}$	none
		$25 \text{ mm} < x \leq 75 \text{ mm}$	Low Shoulder signs (3.2-km spacing)
	$< 45 \text{ mph}$	$75 \text{ mm} < x \leq 600 \text{ mm}^{(4)}$	Place channelizing devices at 15-m spacing
	$\geq 45 \text{ mph}$	$75 \text{ mm} < x \leq 600 \text{ mm}$	Place channelizing devices at 30-m spacing
	all	$> 600 \text{ mm}^{(5)}$	Closure using temporary traffic barrier
$> 2.4 \text{ m}$ to the work zone clear zone ⁽³⁾	$< 45 \text{ mph}$	$300 < x \leq 600 \text{ mm}^{(4)}$	Place channelizing devices at 15-m spacing
	$\geq 45 \text{ mph}$	$300 \text{ mm} < x \leq 600 \text{ mm}$	Place channelizing devices at 30-m spacing
	all	$> 600 \text{ mm}^{(5)}$	Closure using temporary traffic barrier

Notes:

⁽¹⁾ Place channelizing devices and/or temporary barrier at the same level as the traveling lane or shoulder profile.

⁽²⁾ Channelizing devices may be placed at the drop-off elevation to preserve lane width. Raise the reflective area and warning light (if required) to the elevation above traveling lane or shoulder profile as per **Highway Standard 701901**.

⁽³⁾ Place channelizing devices or temporary barrier at same level as the side slope profile to be fully visible.

⁽⁴⁾ Length and duration may be exceeded for urban areas when engineering judgment indicates sight distance will be adversely affected by temporary barrier.

⁽⁵⁾ Temporary traffic barrier may be eliminated for stationary operations of less than 24 hours for multilane, and may be eliminated for stationary operations of less than 96 hours per stage for two lanes, based on engineering judgment.

CONDITION 2 — DROP-OFF BETWEEN TRAVEL LANE AND SHOULDER/EDGE OF PAVEMENT (Metric)
Figure 55-2.B

Design Speed	Taper Rate
50 mph (80 km/h) or less	50:1
55 mph (90 km/h)	55:1
60 mph (100 km/h)	60:1
65 mph (110 km/h)	65:1

Note: $L = W \times \text{Taper Rate}$,

where: $L = \text{minimum taper length, ft (m)}$
 $W = \text{width, ft (m)}$

TAPER RATES FOR LANE REDUCTIONS/CLOSURES

Figure 55-2.C

Type of Taper	Taper Length
<u>Upstream Tapers</u>	
Merging Taper	L Minimum
Shifting Taper*	0.5 L Minimum
Shoulder Taper	0.33 L Minimum
Two-way Traffic Taper	100 feet (30 m) Maximum
<u>Downstream Tapers</u> (Optional)	100 feet (30 m) per lane

* May be used for determining buffer zone length.

Notes:

1. Length "L" is determined from Figure 55-2.C.
2. Figure 55-2.E illustrates the various taper types.

TAPER LENGTH CRITERIA FOR CONSTRUCTION ZONES

Figure 55-2.D

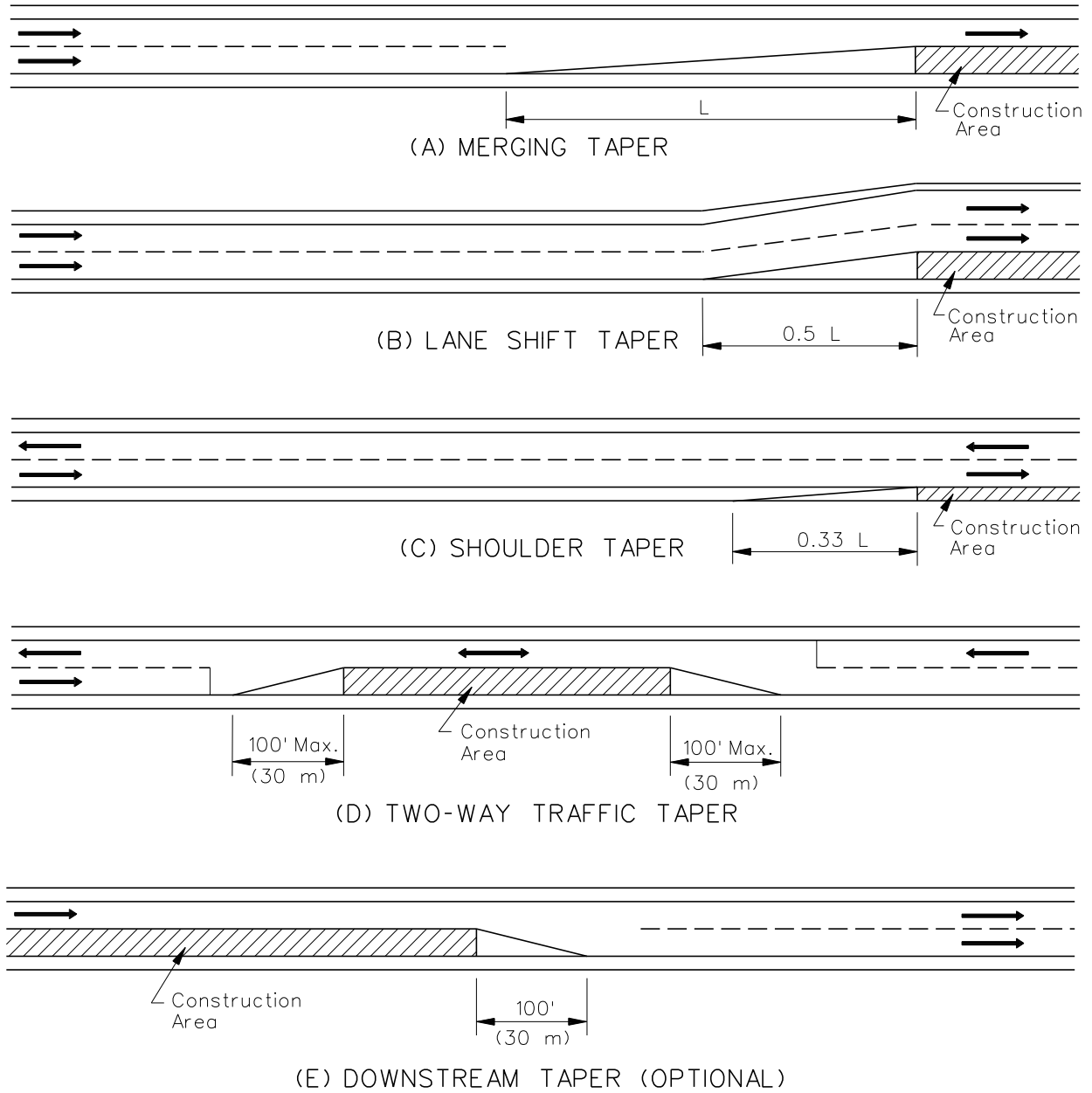

Note: Length "L" is determined from Figure 55-2.C.

**TAPER LENGTH CRITERIA FOR CONSTRUCTION ZONES
(Application)**

Figure 55-2.E

55-2.07 Horizontal Curvature

Design the horizontal curvature using the selected design speed for the work zone (Section 55-2.02) and AASHTO Method 2 for distributing superelevation and side friction to determine the radius and superelevation rate of the horizontal curve. In this Method, superelevation is introduced only after the maximum allowable side friction has been reached. When compared to AASHTO Method 5, this approach typically results in no superelevation on flatter curves (i.e., maintaining the normal crown through the curve) and reduced rates of superelevation on the majority of other curves. Figure 55-2.F provides the minimum radii for retention of the normal crown section for horizontal curves through work zones based on AASHTO Method 2 and a typical cross slope of $\frac{1}{4}$ in/ft (2%). Figure 55-2.G allows the designer to determine the proper combination of curve radius and superelevation rate to meet the work zone design speed where the normal section cannot be retained. For other horizontal curvature elements (e.g., superelevation transition lengths), the criteria presented in Chapter 32 are applicable to work zones, as practical.

Where it is necessary to use the shoulder as a travel lane in the work zone, the shoulder cross slope may create a problem on horizontal curves; i.e., the shoulder slope may need to be modified for superelevation based on Figure 55-2.G, although the traveled way portion can retain the normal crown section through the curve based on Figure 55-2.F. Consider one or more of the following options to alleviate this problem:

- rebuild the shoulders to provide a cross slope equal to that of the adjacent travel lane;
- install advisory speed plate signs for the horizontal curve based on Figure 55-2.G;
- install rumble strips in advance of the temporary travel lane on the shoulder;
- restrict large vehicles (e.g., trucks, buses) from using the temporary travel lane; and/or
- detour large vehicles to other facilities.

55-2.08 Vertical Curvature

Design sag vertical curves in work zones using the selected work zone design speed and the comfort criteria presented in Section 33-4. The comfort criteria are based on the comfort effect of change in vertical direction through a sag vertical curve due to the combined gravitational and centrifugal forces. In general, riding through a sag vertical curve is considered comfortable when the centripetal acceleration does not exceed 1 ft/s^2 (0.3 m/s^2).

55-2.09 Cut and Fill Slopes

Where practical, design temporary cut and fill slopes to meet the design criteria presented in Chapter 34. However, for work zones, 1V:3H front slopes may be used where there is sufficient clear zone available at the bottom of the slope; see Section 55-4.03. The use of steeper front slopes may be considered on a case-by-case basis but may require the installation of roadside barriers or vertical panels.

US Customary			
Work Zone Design Speed, V	f _{max} (Open-Roadway Conditions)	Normal Crown Section Minimum Radii, R _{min} (e = -1.5% to -2%)	Superelevated Section
20 mph	0.27	105 ft	See Figure 55-2.G
25 mph	0.23	200 ft	
30 mph	0.20	335 ft	
35 mph	0.18	510 ft	
40 mph	0.16	760 ft	
45 mph	0.15	1040 ft	
50 mph	0.14	1390 ft	
55 mph	0.13	1835 ft	
60 mph	0.12	2400 ft	
65 mph	0.11	3130 ft	
Metric			
Work Zone Design Speed, V	f _{max} (Open-Roadway Conditions)	Normal Crown Section Minimum Radii, R _{min} (e = -1.5% to -2%)	Superelevated Section
30 km/h	0.28	27 m	See Figure 55-2.G
40 km/h	0.23	60 m	
50 km/h	0.19	116 m	
60 km/h	0.17	189 m	
70 km/h	0.15	297 m	
80 km/h	0.14	420 m	
90 km/h	0.13	580 m	
100 km/h	0.12	787 m	
110 km/h	0.11	1059 m	

Notes:

1. Curve Radii. Radii for both Figures 55-2.F and 55-2.G are calculated from the following equation:

$$R = \frac{V^2}{15(e + f)} \quad (\text{US Customary}) \qquad R = \frac{V^2}{127(e + f)} \quad (\text{Metric})$$

Values for design in Figure 55-2.F have been rounded to the nearest 5 ft (1 m) increment.

2. Normal Crown Section. The data in the above chart is provided based on the normal crown section being maintained throughout the horizontal curve (to the left), a superelevation rate of -2%, and assuming a typical cross slope of 1/4 in/ft (2%). Therefore, the R_{min} column with e = -2% presents the minimum radii that can be used when retaining the normal section through the horizontal curve.

MINIMUM RADII FOR HORIZONTAL CURVES RETAINING NORMAL CROWN SECTION (Work Zones)

Figure 55-2.F

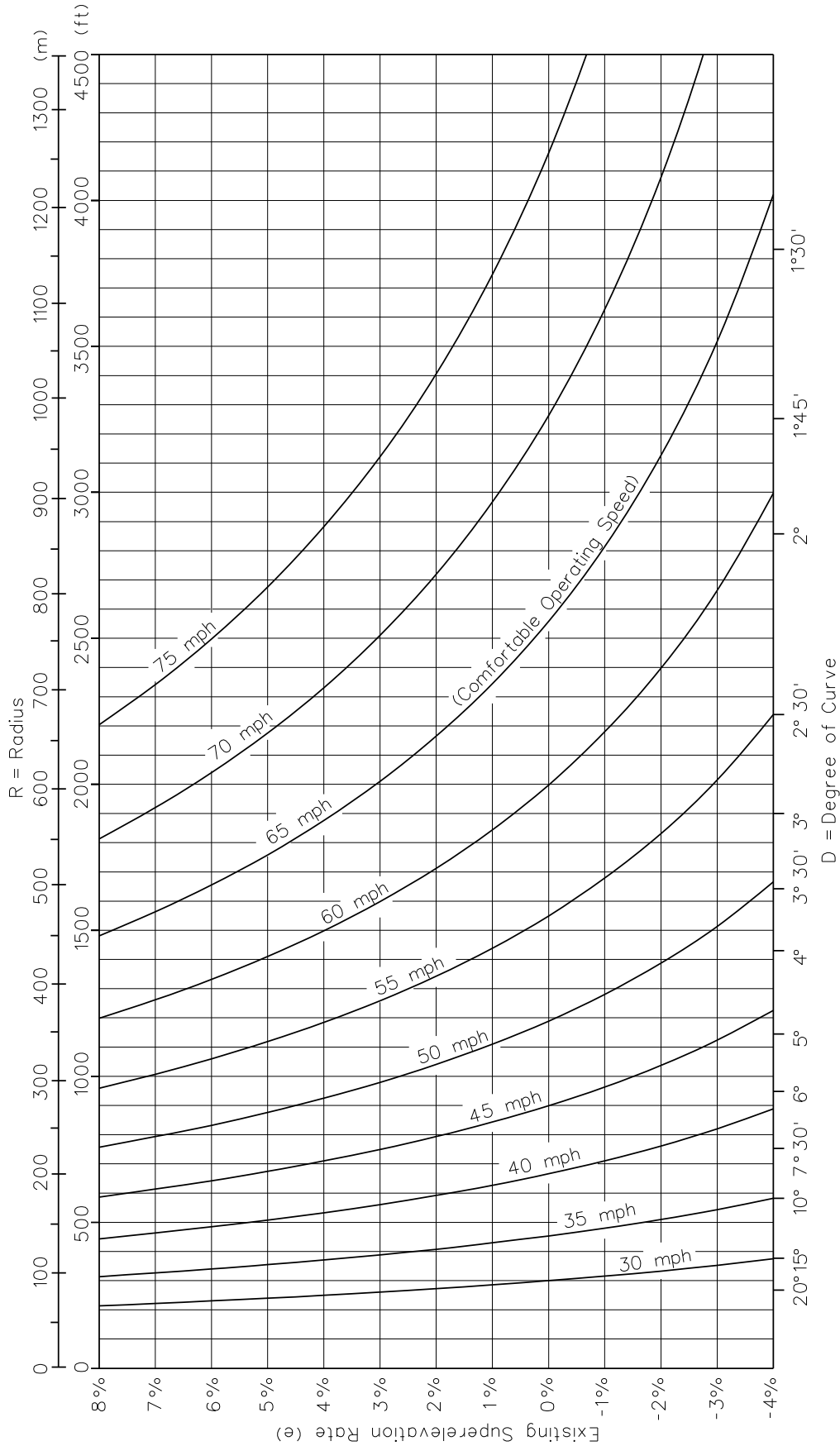

MINIMUM RADII AND SUPERELEVATION RATES FOR HORIZONTAL CURVES (Work Zones)

Figure 55-2.G

- Although detours rarely involve excavation (i.e., cut), 1V:3H cut slopes are generally acceptable in place of the flatter slopes presented in Chapter 34. The use of slopes steeper than 1V:3H for cut depths less than 10 ft (3.0 m) may be acceptable under restrictive conditions. Soil conditions in cut sections will require an investigation to determine their stability.

The anticipated traffic volumes and the length of time the detour will be in place should be weighed in determining final cut and fill slopes. In all cases, stable embankment material must be used and placed according to the *Standard Specifications*.

55-2.10 Pavement Design

The pavement design objective for crossovers, runarounds, local route detours, etc., is to provide, as practical, maintenance-free pavement for its intended life. Note that the pavement for crossovers and runarounds needs to support the expected truck traffic through the work zone. An indication of the required pavement depth can be obtained by preparing a structural pavement design according to Chapter 54 and by using a minimum design period of one year for a single-season detour or five years for over-the-winter detour. The final pavement thicknesses will be based upon a pavement design analysis and previous district experience with similar detour conditions (e.g., soil types, seasons of detour use, truck volume, initial cost, restoration costs).

Typically, crossovers and runarounds are designed using a hot-mix asphalt surface. In high-volume situations, it may be advisable to use full-depth hot-mix asphalt on the detour. Medium-volume situations may warrant a stabilized granular base or an aggregate base with a hot-mix asphalt surface course. In low-volume situations, an aggregate base with some type of surface treatment (e.g., oil and chip) may be an acceptable design to provide maintenance-free pavement. A minimum thickness of 8 in (200 mm) is recommended for aggregate bases and a minimum 3 in (75 mm) of Superpave or Class B is recommended where a HMA surface course is used. As an alternative, a non-reinforced concrete pavement may be used. If non-reinforced concrete pavement is used, investigate the practicality of using lesser quality, local materials in the concrete. Long-term performance is usually not critical in these situations. If the detour will be used through winter, then a HMA surface is recommended.

55-2.11 Temporary Bridges

Where a temporary bridge is required and complete plans for the temporary bridge are not furnished, specify in the traffic control plans or special provisions the general location, roadway width, distance to be spanned, required load capacity, and any other known pertinent design features for the temporary bridge. This information will allow the contractor to bid and submit plans for the Engineer's approval after an award is made, as specified in the *Standard Specifications*.

In special cases, where the district determines the situation dictates a special design, the district may include in the project plans complete design plans for the temporary bridge. Upon request,

the Bureau of Bridges and Structures will prepare these. However, because most contractors are equipped with precast bridge elements and can readily bid and furnish temporary bridges that will meet the Department's criteria, keep the preparation of these special designs by the Department to a minimum.

55-2.12 Crossovers to Remain in Place

A cost savings may be realized if some crossovers on freeway projects are left in place after the project is completed. Because these crossovers are designed to carry Interstate traffic, they are constructed with a high-type pavement that adds to the cost. If crossovers are left in place, this cost may be partially recovered as a cost savings to future construction. Crossovers also leave options open for emergency construction and remain available for future transportation operations plans, including incident management.

Crossovers left in place must be closed with positive separation when not in use, unless the opening is designed to be left open and an exception is obtained from FHWA. Consult the *AASHTO Roadside Design Guide* for information on the design, cost, and maintenance of openings in median barriers for openings in crossovers.

The following are some examples where it may be advisable to leave temporary crossovers in place:

1. Major River Crossings. At these locations, there is usually one preferred location where a crossover can be placed and any future work would require the rebuilding of the same configuration.
2. Locations With Physical Constraints. In some instances, certain factors (e.g., sight distance problems, closely spaced structures, nearby interchanges, elevation differences between lanes) limit where a crossover can be built. Even though projects may be at different locations, the location of a crossover may be set by these limitations.
3. Future Projects in Same Area. If structure work is scheduled for one year and roadway work anticipated in the next five years, the same crossover may be used for both projects. Another example would be a series of structures that are rehabilitated over several years.

When encountering situations as outlined above, the designer should:

- give consideration to leaving the temporary crossovers in place after the project is completed,
- include provisions in the contract to close the crossover during the time it is not in use,
- discuss these provisions at the regular coordination meeting, and
- obtain FHWA and Central Office concurrence.

55-3 DESIGN RECOMMENDATIONS

The following are specific design recommendations for lane and shoulder closures, two way traffic on divided highways, runaround detours, local route detours, stage construction of two lane two way bridges and multilane bridges, reduced traffic control for road closure, and Interstate work zones.

55-3.01 Lane/Shoulder Closures

Lane and/or shoulder closure is often the most common type of traffic control. The *Highway Standards* provide several Traffic Control Standards for lane and shoulder closures. In addition, consider the following:

1. Traffic Control Devices. Section 55-5 and the *Highway Standards* provide Department criteria for the placement of traffic control devices.
2. Speeds. See the Bureau of Operations "Policy for Establishing and Posting Speed Limits on the State Highway System" for guidance on posting speeds in work zones.
3. Tapers. Lane closures, lane width reductions and lane shifts require the use of transition tapers to safely shift traffic around the encroaching restriction. Section 55-2.05 and the *Highway Standards* provide the criteria for taper rates and lengths for work zones.
4. Lane Widths. Section 55-2.03 provides the Department's criteria for reduced lane widths.
5. Sight Distance. Desirably, provide decision sight distance to the beginning of the lane closure or transition; see Sections 31-3.02, 32-4, and 33-4.
6. Lane Closure Length. Keep the length of a lane closure to a minimum so that motorists are not passing long sections of closed lanes where no work activity is occurring.
7. Roadside Safety. Do not use roadside barriers as transition devices. Where temporary roadside barriers are used, provide sufficient distance between the channelization devices and the roadside barrier to allow an errant motorist to safely return to the traveled way. Roadside barriers (e.g., temporary concrete barrier) may be used as channelization devices beyond the taper. When shifting traffic next to roadside barriers, the shy distance, as discussed in Section 38-6.02, desirably should be provided.
8. Bridges. Sections 55-3.05 and 55-3.06 discuss the criteria for lane closures on bridges.
9. Interstate Projects. Section 55-3.08 discusses additional factors to consider on Interstate projects.

55-3.02 Two-Way Traffic on Divided Highways

Because of the higher traffic volumes and higher speeds on multilane facilities, use special care in the design of these work zones. In these cases, safety considerations are usually more important than costs. In addition to Traffic Control Standard 701416, the following provides several design considerations for this application:

1. **Design Speed.** The design speed should be no more than 10 mph (15 km/h) below the posted speed limit before the construction zone. See the Bureau of Operations "Policy for Establishing and Posting Speed Limits on the State Highway System" for guidance on posting speeds in work zones.
2. **Length.** The optimum segment length of two-way traffic on divided highways is less than 4 miles (6 km). Where segments exceed 4 to 5 miles (6 to 8 km), operational efficiency may be reduced as traffic backs up behind slower vehicles.
3. **Sight Distance.** Adequate sight distance should be provided for motorists approaching the crossover. Desirably, this should be decision sight distance. For additional guidance, see Sections 31-3.02, 32-4, and 33-4. Traffic should not be diverted over to other lanes at locations not clearly visible to approaching motorists (e.g., near bridges, at crest vertical curves).
4. **Interchanges.** For interchanges, consider the following:
 - a. **Access.** Desirably, maintain access to all interchange ramps even if the work space is in the lane adjacent to the ramps. Additional crossovers for the purpose of maintaining full interchange access may be required. If interchange access is not feasible or presents a capacity problem, close the ramp and provide detour signing for alternative routes. The designer should review the safety aspects and conduct a capacity analysis to determine the appropriate action.
 - b. **Local Coordination and Emergency Services.** Where ramp closures are deemed necessary, conduct early coordination with local officials and emergency service having jurisdiction over the affected crossroads or streets. Use newspapers, radio, television, and changeable message signs to alert commuting motorists.
 - c. **Deceleration and Acceleration Lengths.** Ensure that sufficient deceleration and acceleration distances are maintained where there is work in the vicinity of interchange ramps. If this is not practical, additional traffic control devices or ramp closure may be required.
5. **Crossovers.** Because of the unexpected movements, special care must be given to the design of crossovers. Temporary concrete barriers and the excessive use of traffic control devices cannot compensate for a poor geometric design of crossovers. Consider the following when designing crossovers:
 - a. **Design Speed.** The crossover should have a design speed that is no more than 10 mph (15 km/h) below the posted speed limit before the construction zone.

- b. Transitions. Tapers for lane drops should not be contiguous with the crossover (i.e., provide a buffer area between the lane closure and the crossover). See Section 55-2.05 for acceptable taper rates and lengths.
 - c. Width. For one-lane, one-way operations, the lane width through the crossover portion should be 16 ft (5.0 m) with 2-ft (600-mm) wide left and right shoulders. For multilane and/or multidirectional operations, each lane width should be 12-ft (3.6-m) wide with 2 ft (600 mm) left and right shoulders.
 - d. Pavement Design. Section 55-2.10 presents guidelines for determining the pavement design of the crossover.
 - e. Roadside Safety. Provide a clear recovery area or buffer area adjacent to the crossover prior to the work zone.
 - f. Crossovers to Remain In Place. Under some circumstances, it may be cost effective to retain the crossover after the project has been complete. See Section 55-2.12 for additional guidance.
6. Roadside Safety Appurtenances. Where traffic is diverted onto the opposing roadway, consider the effect this will have on the operational characteristics of roadside safety appurtenances. For example, existing trailing ends of unprotected bridge rails may require approach guardrail transitions or impact attenuators, or blunt guardrail end terminals may require protection with an acceptable end treatment if these appurtenances are within the work zone clear zone. Appurtenances are discussed in Section 55-4.02.
 7. Signing. In addition to the signing shown in the Highway Standards, include signing prior to the crossover to indicate the length of the two-way, two-lane section. In addition, provide signing within the two-lane section to indicate the remaining distance of the two-lane section (e.g., NEXT X MILES). Place this sign below the two-way traffic signs.
 8. Channelization Devices. Traffic Control Standards 701416 and 701431 present the general criteria for the placement of channelization devices within and between crossovers. Temporary traffic barriers, barricades or drums may be used to channel traffic within the crossovers. Between crossovers, temporary traffic barrier is used to separate traffic between the crossovers except as discussed below. Signs, centerline striping, and raised pavement markers, either alone or in combination, are not considered separation devices. Consider the following:
 - a. Short-Duration Projects (120 Consecutive Hours or Less). Type II barricades or drums may be used as separators. Cones may be used for daylight only operations.
 - b. Longer-Duration Projects (Greater than 120 Consecutive Hours). Use temporary traffic barrier on all projects other than those listed in Item c. below.

- c. Urban (Posted Speed 40 mph or less). Cones, drums, or barricades may be used as separators for urban projects. Consider flexible delineators for long term. Under special circumstances (e.g., winter work), it may be necessary to omit devices to allow for snow removal.
- d. Ramps. Where ramps or side roads intersect a two-lane, two-way operation, special traffic-accommodation details must be developed. Consult the Bureau of Operations for guidance in these situations.
9. Nighttime Safety for Crossovers. Positive guidance is needed in crossovers. Consider the use of temporary highway lighting, or wet reflective pavement markings within the crossover in addition to other traffic control measures and devices.
- a. Lighting. Consider providing temporary highway lighting where the crossover will be in place for longer than three weeks and one or more of the following conditions exist:
- Existing continuous highway lighting will be removed because of the construction activities at or adjacent to the proposed median crossover.
 - The median crossover will be located adjacent to a lighted interchange.
 - The absence of highway lighting will contribute to an already less than desirable condition (e.g., inadequate sight distance, inadequate geometrics) required by existing conditions that will not allow an adequate design through the median crossover.
 - The crossover will be used on a roadway section having an ADT of 10,000 or more.
- The crossover should be capable of safe operations during blackouts caused by construction activities, adverse weather, or traffic crashes.
- See Chapter 56 and/or contact BDE for details on the lighting design. The request for the lighting design should include the:
- location of power source,
 - location of any existing lighting units,
 - geometrics of proposed median crossovers, and
 - length of time it is anticipated that the temporary lighting will be required.
- b. Wet Reflective Pavement Markings. Consider the use of wet reflective pavement markings for crossovers that meet the following conditions:
- temporary highway lighting is impractical due to cost or geometrics; and
 - adverse geometrics, complexity of the crossover, or previous experience indicate a need for greater positive guidance to the motorist.

10. Emergency Access. Work with local emergency service agencies to ensure access throughout the project. It is important that police, fire, ambulance, and towing services have access without having to travel excessive adverse miles.

55-3.03 Runaround Detours

In addition to the criteria in the *Highway Standards*, runarounds and specially built detours should meet the geometric and roadside safety criteria presented in Sections 55-2 and 55-4 and the following guidelines:

1. Layout. Figure 55-3.A illustrates a typical layout for a runaround detour. Figure 55-3.B illustrates typical cross sections for a runaround detour.
2. Design Speed. The runaround should have a design speed that is no more than 10 mph (15 km/h) below the posted speed limit before the construction zone.
3. Width. At a minimum, provide a 22 ft (6.6 m) traveled way width. If there are significant multiple-unit trucks to affect the design, use the traveled way widths presented in Figure 55-3.C. Also, provide a minimum 2 ft (600 mm) shoulder on each side.
4. Pavement Design. Section 55-2.10 presents guidelines for determining the pavement design.
5. Horizontal Alignment. Desirably, the horizontal curve connecting the runaround to the existing roadway should be sufficiently flat so that superelevation will not be required. See Section 55-2.07 for the design of horizontal curves in work zones.
6. Vertical Alignment. See Section 55-2.08 for the minimum vertical curvature criteria that may be used on runarounds.
7. Sight Distance. Design the runaround to meet the sight distance criteria in Section 55-2.06. Check to ensure that adequate sight distance is available through the horizontal and vertical curves.
8. Traffic Control Devices. Traffic Control Standard 701331 and the Standard Specifications provide the minimum criteria for placement of traffic control devices prior to and through the runaround. Temporary rumble strips, reflectors, and/or additional warning devices may be required where unusual site conditions warrant and/or where the design speed on the runaround is more than 15 mph (25 km/h) less than the approach posted speed.

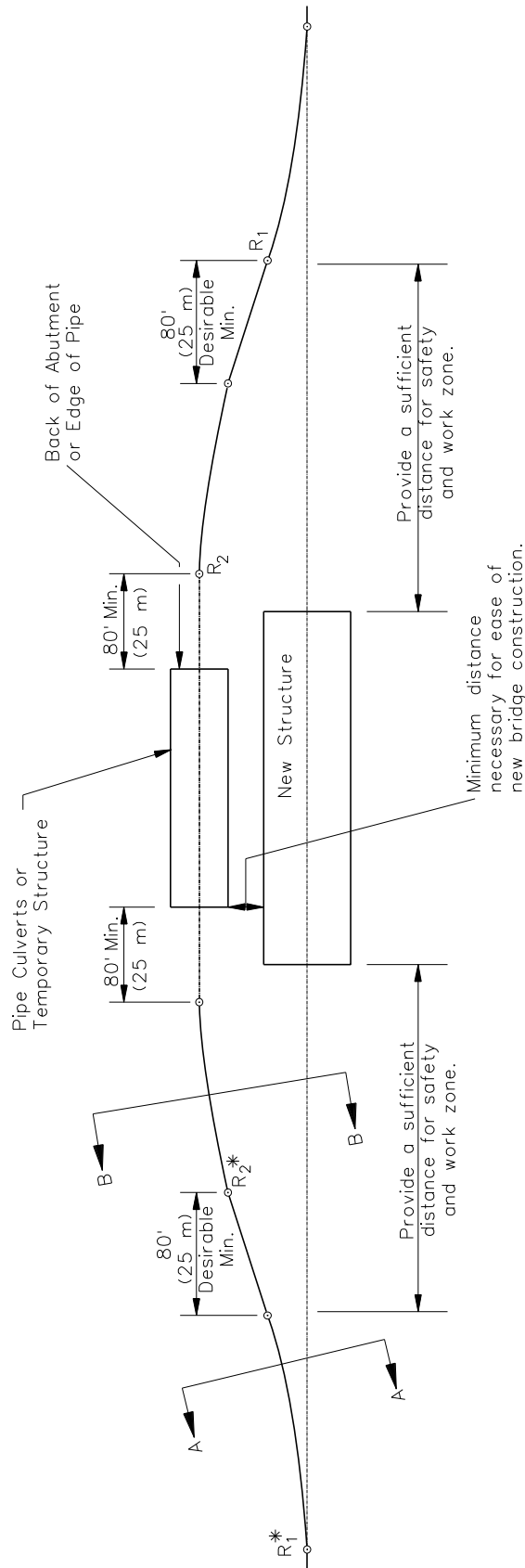

*See Section 55-2.07.

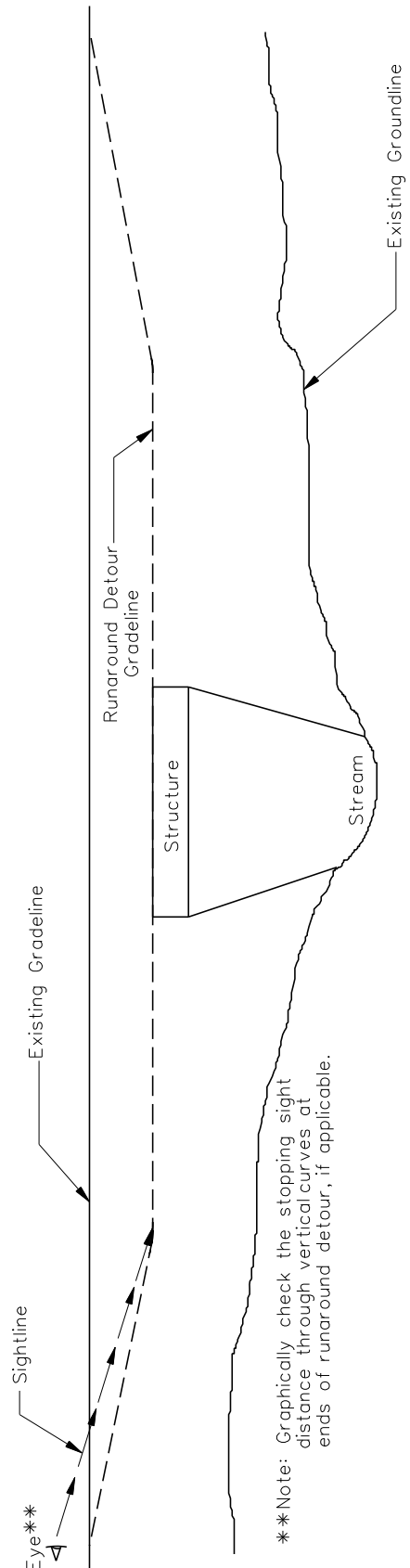

**Note: Graphically check the stopping sight distance through vertical curves at ends of runaround detour, if applicable.

TYPICAL RUNAROUND LAYOUT

Figure 55-3.A

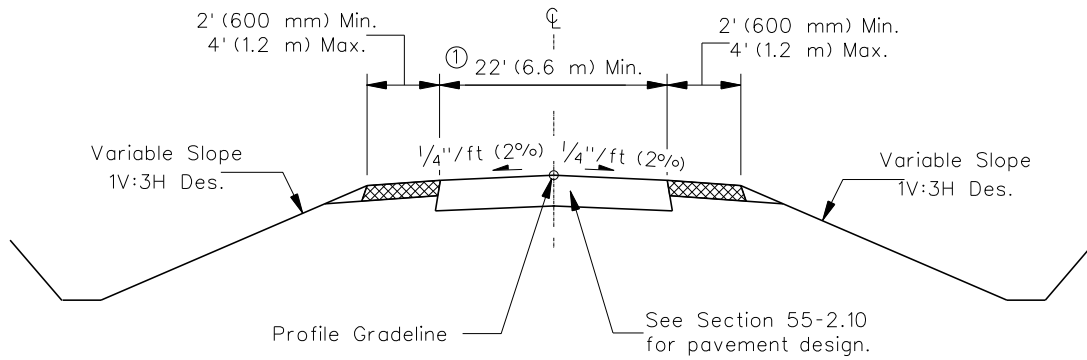

Section A - A

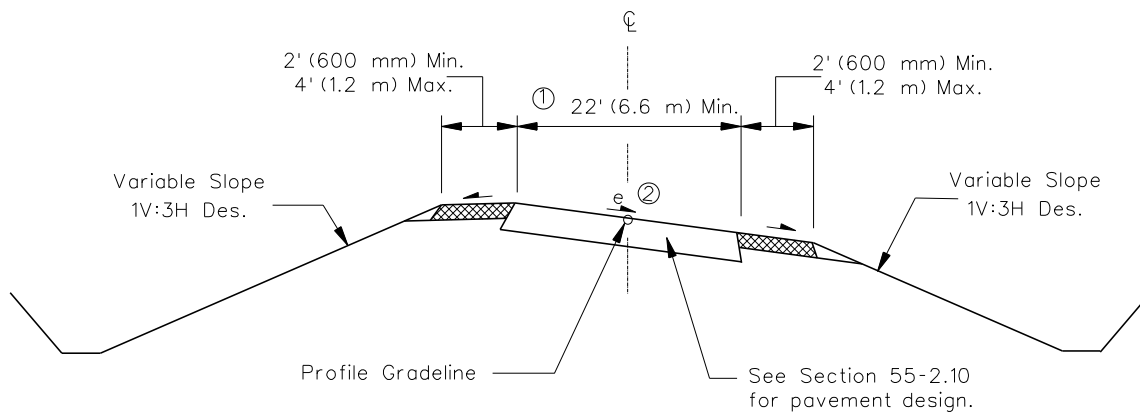

Section B - B

- ① Where there are significant multiple-unit trucks, see Figure 55-3.C for traveled way widths.
- ② See Section 55-2.07 for superelevation design.

TYPICAL CROSS SECTIONS FOR RUNAROUND DETOUR

Figure 55-3.B

US Customary			
Roadway Width (ft)			
Radius on Inner Edge of Traveled Way (ft)	Traffic Condition		
	A	B	C
150	26	29	32
200	26	28	30
300	25	28	29
400	25	27	28
500	22	22	22
Tangent	22	22	22
Metric			
Roadway Width (m)			
Radius on Inner Edge of Traveled Way (m)	Traffic Condition		
	A	B	C
50	7.9	8.8	9.5
75	7.7	8.5	8.9
100	7.6	8.3	8.7
125	7.6	8.2	8.5
150	6.6	6.6	6.6
Tangent	6.6	6.6	6.6

Note:

Traffic Condition A — Predominantly P vehicles, but some consideration for SU vehicles.

Traffic Condition B — Sufficient SU vehicles to govern design, but some consideration for semitrailer vehicles (5%-10% SU and 0%-3% semitrailer vehicles).

Traffic Condition C — Sufficient semitrailer vehicles to govern design (over 3% semitrailer vehicles).

**RUNAROUND DETOUR ROADWAY WIDTHS
(Two-Way, Two-Lane Operations)**

Figure 55-3.C

9. Bridges. Temporary structures should be at least 2 ft (600 mm) wider than the approach runaround roadway. Provide appropriate roadside safety protection at the ends of temporary bridges. Design waterway openings based on the criteria of the Bureau of Bridges and Structures.
10. Ditches. Where construction of a runaround detour is over an existing ditch that involves minimal cuts and fills, undercut the ditch by a minimum of 2 ft (600 mm) to remove any unstable material. However, each site must be examined on a project-by-project basis to determine if additional excavation will be required.
11. Side Slopes. For large streams or rivers, the runaround may be in a cut section. Ensure that adequate sight distance is available through the cut section. For additional guidance on side slopes, see Section 55-2.09.

55-3.04 Local Route Detours

Once it has been determined to use a local road as a detour, the designer should consider the following guidelines for local route detours:

1. Widths. Figure 55-3.D presents the minimum and desirable traveled way and roadway widths for a local route detour. These widths are based on the expected average daily traffic during the detour and the detour posted speed.
2. Intersections. Existing rural intersections may need to be converted from a yield or a no-control intersection to a stop-controlled intersection. Note that local drivers may be accustomed to using the route without stop conditions. Therefore, provide adequate advance warning of the new stop condition.
3. Pavement Design. The pavement design of existing local routes may need to be upgraded to meet the increased traffic and truck volumes. See Section 55-2.10 to determine the acceptable pavement design for local detour routes.
4. Agreements. Before a local road can be used as a detour, a Joint Agreement or Letter of Understanding must be executed with the local officials having jurisdiction over the road. This will require conducting a joint inspection with the officials prior to construction to determine the existing condition of the road and reaching an agreement on plans for restoration of the local route to an acceptable condition after the detour is removed. See Chapter 5 for further guidance on agreements.

US Customary									
Detour Posted Speed (mph)		Current ADT Under 400		Current ADT 400-999		Current ADT 1000-2999		Current ADT 3000-5000	
		Traveled Way (ft)	Roadway Width (ft)	Traveled Way (ft)	Roadway Width (ft)	Traveled Way (ft)	Roadway Width (ft)	Traveled Way (ft)	Roadway Width (ft)
30-35	Min.	18	22	18	24	20	24	22	26
	Des.	—	—	20	24	22	26	24	28
Over 35		18	22	18	24	22	26	24	28
Metric									
Detour Posted Speed (mph)		Current ADT Under 400		Current ADT 400-999		Current ADT 1000-2999		Current ADT 3000-5000	
		Traveled Way (m)	Roadway Width (m)	Traveled Way (m)	Roadway Width (m)	Traveled Way (m)	Roadway Width (m)	Traveled Way (m)	Roadway Width (m)
30-35	Min.	5.4	6.6	5.4	7.2	6.0	7.2	6.6	7.8
	Des.	—	—	6.0	7.2	6.6	7.8	7.2	8.4
Over 35		5.4	6.6	6.0	7.2	6.6	7.8	7.2	8.4

MINIMUM TRAVELED WAY AND ROADWAY WIDTHS

Figure 55-3.D

5. **Bridges.** Examine all structures on the local detour route to ensure that they are structurally adequate to accommodate the expected traffic and truck volumes. When determining the structural adequacy, consider the following:
 - a. **Widths.** Where two-way operation is proposed, the minimum horizontal clearance for structures to remain in place along the detour route is 24 ft (7.2 m). Where low truck volumes are anticipated (i.e., where semitrailers are less than 5% and SUs are less than 10% of ADT) and expected traffic volume on the detour route is less than 1,000 ADT, the minimum horizontal clearance that may remain is 22 ft (6.6 m).
 - b. **One-Lane Bridges.** Where it has been determined that it is feasible to retain a one-lane bridge on a local route detour, ensure that the appropriate traffic control devices and signing are provided to delineate the transitions and bridge.
 - c. **Design Load.** Where the load-carrying capacity of a structure on the detour route is questionable, request the Bureau of Bridges and Structures to analyze the structure to determine if it is acceptable. In some cases, it may be necessary to specify weight restrictions (e.g., load limit, one truck at a time) for the bridge. However, where feasible, avoid specifying weight restrictions. When it is not feasible to use a bridge for truck traffic, provide a marked alternative truck route.

- d. New Structures. Where an existing structure does not meet either the load limit requirements and/or width requirements necessary to remain in place, a new structure should be provided and designed according to the bridge policies in the *Bureau of Local Roads and Streets Manual*. Design traffic will be the current ADT on the local route rather than the ADT on the route during its use as a detour. If this is not feasible, provide a marked alternative truck route.
6. Ditches. To improve drainage and increase subgrade stability, existing ditches may need to be cleaned and deepened before the new pavement structure is built.
7. Roadside Safety. Review the local route to determine if new or upgrading existing roadside safety hardware is necessary. Any improvements to the existing roadside protection should be consistent with the local road classification, the temporary nature of the detour route, and the detour design speed. For additional guidance, see Section 55-4 and Chapter 38.

55-3.05 Stage Construction of Two-Lane, Two-Way Bridges

Traffic Control Standards 701316 and 701321 present the general traffic control criteria for stage construction on a two-lane, two-way structure (i.e., alternating traffic using one lane). In addition to the *Highway Standards*, consider the following guidelines:

1. Maximum Distance. Figure 55-3.E presents the recommended maximum closure distance, excluding tapers, that should be considered for this operation. Where longer distances are necessary, evaluate additional methods to improve operations.
2. Width. Section 55-2.03 presents the minimum widths that should be considered for one-lane roadways.
3. Structure Type. Section 13-2.02(b) contains guidelines for stage construction of various structure types.
4. Temporary Traffic Signals. The required method for alternating traffic across the structure is with temporary traffic signals. Section 55-5.04 and the Standard Specifications provide the criteria for these traffic signals.
5. Rumble Strips. Consider providing temporary rumble strips and/or additional warning devices in addition to the standard traffic control devices where there is restricted alignment and/or sight distance.
6. Temporary Bridge Rails. Under some circumstances, it will be necessary to provide temporary bridge rails, temporary concrete barriers, or temporary concrete barriers on the structures. Before using temporary concrete barrier across a structure, consult with the Bureau of Bridges and Structures to ensure the bridge deck can adequately support the barriers. Request the details for temporary bridge rails or temporary concrete barriers on the structure from the Bureau of Bridges and Structures.

Detour ADT	Recommended Maximum Distance
> 8000	300 ft to 500 ft (100 m to 150 m)
≥ 5000 to ≤ 8000	500 ft to 800 ft (150 m to 250 m)
< 5000	800 ft to 1000 ft (250 m to 300 m)

**RECOMMEND MAXIMUM DISTANCE FOR STAGE CONSTRUCTION
(Bridges)**

Figure 55-3.E

55-3.06 Stage Construction of Multilane Bridges

In addition to Traffic Control Standard 701401, consider the following guidelines when using stage construction on multilane bridges:

1. Widths. See Section 55-2.03 for the minimum lane widths allowed.
2. Traffic Control Devices. In addition to the criteria presented in the Highway Standards, consider providing additional traffic control devices (e.g., wing barricades, regulatory speed signs, changeable message signs) where there are high-traffic volumes and/or restricted geometric conditions.

55-3.07 Reduced Traffic Control for Road Closed to Through Traffic

Where a highway or bridge is closed to through traffic, the *Illinois Highway Code* allows the Department to specify alternative procedures, if desired, for flagging and controlling the local traffic through the work zone. The designer must specify the option for reduced traffic control in the plans and provide the average daily local traffic in the contract, otherwise the contractor will be required to provide the same level of traffic control within the section of road closed to through traffic as would be required for open-highway conditions.

The Department's criteria in the *Standard Specifications* for reduced traffic control is based on the expected traffic volumes through the work zone. The designer will be responsible for determining these traffic volumes and incorporating this information within the traffic control plans. The estimated traffic volumes may vary at different locations within the work zone or during separate construction phases. For these situations, list the expected traffic volumes for each location and/or phase. This will allow the contractor to adjust the traffic control accordingly.

55-3.08 Interstate Work Zones

Incorporate the following items, as appropriate, into traffic control plans for Interstate projects involving lane closures:

1. Communication with Motorists. To inform motorists of possible backups, delays, closures, etc., review Section 13-3.02 for on-site strategies.
2. Other Traffic Control Device Requirements. In addition to the criteria presented in Section 55-4, provide extra attention to the following:
 - a. Lighting. Provide temporary lighting at all Interstate crossovers for two-way, two-lane operations; see Chapter 56 and/or contact BDE for details on the lighting design. The request for the lighting design should include the:
 - location of power source,
 - location of any existing lighting units,
 - geometrics of proposed median crossovers, and
 - length of time it is anticipated that the temporary lighting will be required.
 - b. Temporary Traffic Barriers. Use temporary traffic barrier to separate two-way, two-lane traffic and to extend work space as required for positive protection. See Section 55-4.01 for positive protection guidelines.
 - c. Guide Signs. In two-way, two-lane operations, include signing with the distances remaining in the two-lane section (e.g., NEXT X MILES). This can reduce motorist frustration level. Place this sign below the two-way traffic signs.
 - d. Review. If the TCP is not part of a TMP that will be reviewed by the Bureau of Safety Engineering, request the Bureau of Operations to review the traffic control plans prior to advertisement to ensure the above requirements are met.
3. Reducing Lane Closures. Develop the traffic control plan so that lane closures can be kept to a minimum. Consider the following to reduce the time and length of lane closures and to meet mobility goals.
 - a. Overnight Closures. Where practical, specify the use of Traffic Control Standard 701406 (Daylight Work Only) versus Traffic Control Standard 701401 (Overnight Closures). Resurfacing, shoulder work, most underdrains, and moving work can be accomplished under Standard 701406. Do not allow contractors to use Standard 701401 in lieu of Standard 701406 at their expense.
 - b. Time Restrictions. Consider the scheduling strategies listed in Section 13-3.04.
 - c. Special Provisions. Figure 55-3.F provides a sample Special Provision that may be used for lane closures to limit the number of days of lane closure by the contractor.

Lane closures under Traffic Control Standard 701401, except those for structure repairs, shall be limited to a total of a. lane closure days. A day is defined as any day or portion thereof including Saturdays, Sundays, and Holidays, in which a lane closure is in effect. If more than one closure is in effect simultaneously, a day will be charged against each individual lane closure in determining the number of lane closure days used. When adverse weather prevents work from being performed, a day will not be charged.

If quantities for the following pay items are increased, days for lane closures will be increased at the following daily rates:

<u>Pay Item</u>	<u>Daily Rate</u>
-----------------	-------------------

b.

Increases in lane closure days will only be allowed for the specified pay items and at the specified rates. No additional increases will be considered.

If the Contractor fails to open all lanes to traffic within the lane closure days allowed, the Contractor shall be liable to the Department in the amount of \$ c. for each full or partial day of overrun not as a penalty but as liquidated damages. These damages shall be in addition to any liquidated damages charged in accordance with Article 108.09.

Any additional cost to comply with these provisions shall be included in the cost of Traffic Control and Protection, Standard 701401.

Notes to the designer:

- a. The total days should be calculated using those pay items that require overnight closures (e.g., concrete patching, shoulder reconstruction). Items such as resurfacing, bituminous patching, pipe underdrains, cold milling, etc., can typically be done using Standard 701406 and the lanes opened at the end of each day. Once the applicable pay items are determined, working days can be calculated using daily production rates; see Section 66-2.03 Working days would then be multiplied by 7/5 to obtain the calendar days.
- b. List the pay items and daily rates used to determine the total days here.
- c. The daily road user delay cost can be determined according to Section 66-2.04. The length used should be the estimated lane closure length; normally this would be 5 miles (8 km) for concrete patching and 3 miles (5 km) for other operations.

SPECIAL PROVISION FOR STANDARD 701401 LANE CLOSURES

Figure 55-3.F

55-4 ROADSIDE SAFETY

Through a work zone, drivers are often exposed to numerous hazards (e.g., restrictive geometrics, construction equipment, opposing traffic). A total elimination of work zone hazards is impractical. Therefore, the designer must devote special attention to reducing a motorist's exposure to potential hazards. The following sections offer roadside safety criteria that apply only to the roadside elements within the work zone. These criteria do not apply to detours over existing routes.

55-4.01 Positive Protection

Positive protection devices are the devices that contain and/or redirect vehicles and meet the crashworthiness evaluation criteria contained in NCHRP Report 350. This can include approved longitudinal barriers or truck/trailer-mounted attenuators (TMA). Positive protection devices should be considered in work zone situations that place workers at increased risk from motorized traffic and where positive protection devices offer the highest potential for increased safety for workers and road users.

Desirably, the designer should consider traffic control designs that do not require the use of positive protection, minimize the hazard exposure, and maximize the separation of workers and traffic. However, in many work zones, positive protection is needed.

Positive protection is required for the following conditions where work is conducted under traffic:

1. Mobile Operations. Mobile operations are defined as work that moves intermittently or continuously (at approximately 1 mph (1.6 km/h), a walking pace). A mobile operation may be accomplished using the following:
 - a. Multi-lane Highways. Mobile operations on multi-lane highways may be accomplished using a standard lane closure as shown in the *Highway Standards* (or *IDOT Work Site Protection Manual* for IDOT employees) where the lane is closed using signing, arrow boards, and channelizing devices. If a standard lane closure is not used, then positive protection devices (e.g., TMA) may be used to close the lane in advance of the workers. The use of additional signing would be dependent upon the speed and the length of the work and will be in accordance with the *Illinois Manual on Uniform Traffic Control Devices* (ILMUTCD).
 - b. Two-Lane Highways. Mobile operations on two-lane highways will require the use of a positive protection device (e.g., TMA) in advance of the work.

TMA's are acceptable for limited daily work hours consistent with the *IDOT Work Site Protection Manual*.

2. Stationary Operations. Stationary operations are defined as work that occupies a location for more than one hour. In these cases, the work would require a lane closure in accordance with an appropriate *Highway Standard*.

Positive protection devices will be required, based on engineering judgment, for stationary operations conducted under traffic in areas that offer no means of escape from motorized traffic (e.g., tunnels, bridges, bridge painting, narrow medians) as follows:

- Multi-lane highways that occupy a location for more than 24 hours or require multiple days/nights setups exceeding 24 hours to complete, will require the use of temporary longitudinal traffic barriers when no means of escape for workers exists.
- Two-lane highways that occupy a location for more than four days per stage will require the use of temporary longitudinal traffic barriers when no means of escape for workers exists.
- TMA use is permitted in instances where workers are present for only shorter durations in the work zone (e.g., stage shifts, extended time for curing). If workers are present for over 24 cumulative hours duration, consider temporary longitudinal traffic barrier as indicated above, unless TMAs are justified based upon an engineering study.

The following are locations where the designer should consider using positive protection:

- exposed ends of temporary concrete barriers;
- untreated guardrail ends in two-way, two-lane operations;
- bridge piers;
- bridge rail or parapet ends;
- structure foundations (e.g., bridge falsework, sign foundations);
- excavations and rock cuts;
- gap in median between dual bridges;
- excessive pavement edge and shoulder drop-offs (see Figures 55-2.A and 55-2.B); and
- other locations where construction will increase the potential hazards of existing conditions.

Consider the following factors when assessing the need for positive protection:

- duration of construction activity,
- traffic volumes (including seasonal and special event fluctuations),
- nature of hazard,
- length and depth of dropoffs,
- work zone design speed,

- highway functional class,
- length of hazard,
- proximity between traffic and construction workers,
- proximity between traffic and construction equipment,
- adverse geometrics which may increase the likelihood of run-off-the-road vehicles,
- two-way traffic on one roadway of a divided highway,
- transition areas at crossovers, and
- lane closures or lane transitions.

Other factors may apply, and the above list is not considered all inclusive.

Positive protection devices should be used in accordance with the *Highway Standards*, *ILMUTCD*, manufacturers' requirements, and NCHRP Report 350. See Section 55-4.02 for more information. Their use provides greater protection for workers than normal channelizing devices; however, workers should be aware of the limitations of positive protection devices.

When developing the Transportation Operations Plan, designers should take emergency situations into consideration. Emergency situations and traffic incidents should consider use of positive protection devices in accordance with Chapter 6 of the *ILMUTCD*. Incidents lasting more than 24 hours should be evaluated for appropriate use of positive protection devices.

55-4.02 Appurtenance Types

In addition to Chapter 38 and the *Highway Standards*, the following sections provide additional information on the roadside safety appurtenances used by the Department in work zones.

55-4.02(a) Guardrail

Temporary guardrail installations must meet the permanent installation criteria in Chapter 38 and the *Highway Standards*, except as modified in Section 55-4.02(c). For short-term construction projects, the installation of a new temporary guardrail is usually not practical.

55-4.02(b) Temporary Traffic Barrier

Temporary traffic barrier provides protection by separating motorists from the construction site and/or opposing traffic. Temporary traffic barrier may consist of temporary concrete barrier (TCB) or shifting, portable, or movable barrier systems.

When considering temporary traffic barrier, evaluate the following:

1. Purpose. The primary functions of temporary traffic barrier are:
 - to prohibit traffic from entering work areas (e.g., excavations, storage sites);
 - to protect workers and pedestrians;
 - to separate two-way traffic;

- to shield construction elements (e.g., bridge falsework, exposed objects); and
 - to protect motorists from hazards in the clear zone.
2. **Flare Rates.** Temporary traffic barrier located along a tapered alignment should be flared at the rates shown in Figure 55-4.A using the selected work zone design speed. If field conditions are such that these flare rates cannot be used, then consider using a flare rate between 4:1 and 8:1. The length of the taper will be determined based on the length of need requirements; see Section 55-4.03. The approaching end of the TCB along the tapered alignment should desirably extend to a point beyond the construction clear zone. Under restrictive conditions, however, the designer may reduce this offset to the outside edge of the shoulder with an applicable end treatment.
 3. **End Treatment.** Shield the approach end of temporary traffic barrier with an approved end treatment meeting the requirements of NCHRP Report 350, regardless of placement within or outside of the clear zone. Place all end treatments on level ground 1:10 or flatter.
 4. **Test Level.** The application of temporary traffic barrier must match the test level of the product. Consult the *AASHTO Roadside Design Guide*, NCHRP Report 350, and the Bureau of Safety Engineering for further guidance.
 5. **Offset and Deflection.** A minimum offset of 2 ft (600 mm) from the traveled lane is desirable. Check the expected deflection of the temporary traffic barrier against the proposed use. The deflection should not allow the barrier to fall from a drop-off or bridge deck, or intrude into oncoming traffic. However, some barriers may be anchored to reduce deflection. Contact the Bureau of Safety Engineering for information on temporary traffic barrier deflection data and barrier systems that may be anchored. Contact the Bureau of Bridges and Structures for guidance on anchoring barriers to bridge decks.

Work Zone Design Speed	Flare Rate
45 mph (70 km/h) and above	12:1
Less than 45 mph (70 km/h)	8:1

TEMPORARY CONCRETE BARRIER FLARE RATES

Figure 55-4.A

55-4.02(c) End Treatments

Locate any unprotected approach guardrail end (e.g., at breaks for crossovers, emergency vehicle access, or contractor access) at or beyond the construction clear zone or shield it with an appropriate end treatment. Shield the approach end of a temporary traffic barrier as discussed in Section 55-4.02(b). The following discusses several end treatments that can be used:

1. Attenuating Devices. Attenuating devices meeting the requirements of NCHRP Report 350 are acceptable protective end treatments. They also may be considered at point obstacles (e.g., bridge piers) where space is limited. Contact the Bureau of Safety Engineering for guidance on attenuating devices available and physical space requirements needed for installation.
2. Guardrail. The treatments for exposed ends of guardrail include:
 - connection to existing barriers,
 - overlapping barriers,
 - using an approved end terminal,
 - attaching an impact attenuator, or
 - burying the end in the backslope.
3. Sand Barrels. Sand barrels are commonly used to protect the driver from point obstacles (e.g., bridge piers, temporary traffic barrier ends). Due to the size of the array, sand barrels should only be used outside of the traveled way (e.g., on shoulders, in medians). Arrays vary according to the obstacle width and the design speed. The Highway Standards illustrate typical sand barrel applications; however, the designer must confirm that the Highway Standards are applicable to the site. Information on alternative NCHRP Report 350 approved array arrangements can be obtained from the manufacturers' literature. Also note that single-row arrays are not allowed by IDOT policy. Use attenuating devices for areas with limited allowable width.
4. Other. Other IDOT approved end treatments may be applicable. Chapter 38 and the Highway Standards provide information on some of these end treatments used by the Department. Contact BDE or the Bureau of Safety Engineering for further assistance in providing the most applicable end treatment consistent with cost and geometric considerations.

55-4.02(d) Glare Screens

Glare screens may be used in combination with temporary traffic barrier to reduce headlight glare from opposing traffic. Typical applications in work zones are at crossover transitions and in two-way, two-lane operations. In addition to crossovers, consider providing glare screens where:

- the travel lane is within 2 ft (600 mm) of the barrier,
- a high amount of peripheral ambient light exists,
- there is a high volume of truck traffic, and/or
- the vertical or horizontal alignment of the roadway may create a headlight glare problem.

If glare screens are used on curvilinear alignments, ensure that the glare screen installation will not produce below minimum stopping sight distances. For additional glare screen design criteria, see Section 38-7.05.

55-4.03 Design/Layout

Where practical the designer should locate and design temporary roadside safety appurtenances based on the criteria in Chapter 38 (e.g., deflection distance, length of need). However, it is usually not practical nor cost effective to meet these criteria for permanent installations due to the limited time traffic is exposed to construction hazards and the space constraints that are required during construction. The designer must evaluate the exposure time of the hazard in determining the need for installing a roadside safety appurtenance. The following offers several alternatives that should be considered in designing and locating temporary roadside safety appurtenances within work zones:

1. Work Zone Clear Zones. Applying the clear zone distances from Chapter 38 to work zones is often impractical. Therefore, the Department has developed revised work zone clear zone distances, which are presented in Figure 55-4.B. However, the potentially hazardous conditions typically found within work zones warrant the use of considerable judgment when applying these clear zone distances. Note that it is not necessary to adjust the clear zone values presented in Figure 55-4.B for horizontal curvature.

Treat hazards within the work zone clear zone in the same manner as they would be in a conventional clear zone.

2. Embankment Warrants. Figure 55-4.C presents barrier warrants for embankments in work zones.
3. Length of Need. As with new installations, provide a sufficient distance of full-strength barrier prior to the hazard to minimize the potential for a vehicle to run behind the barrier and impact the hazard. For temporary layouts, the length of need can be determined by using an angle of 10° to 15° from the back of the hazard or from the work zone clear zone distance off the traveled way.
4. Flare Rates. Desirably, flare temporary traffic barrier terminals beyond the traveled way to a point outside of the work zone clear zone. Figure 55-4.A presents the desirable flare rates for barrier based on the selected work zone design speed. Use these flare rates unless documented extenuating circumstances render this impractical (e.g., stop conditions, driveways, intersections).

Approach Posted Speed Limit ⁴	ADT	Front Slopes			Back Slopes		
		1:6 or Flatter	1:5 to 1:4	1:3	1:3	1:5 to 1:4	1:6 or Flatter
		Work Zone Clear Zone Distances (ft)					
35 mph or less	Under 750	4-6	4-6	4-6	4-6	4-6	4-6
	750-1500	6-8	8-10	6-8	6-8	6-8	6-8
	1500-6000	6-8	10	8-10	8-10	8-10	8-10
	Over 6000	10	10-12	10	10	10	10
35 - 50 mph	Under 750	6-8	6-10	4-6	4-6	4-6	6-8
	750-1500	10	10-14	6-8	8-10	8-10	10
	1500-6000	10-12	12-16	8-10	10	10	10-12
	Over 6000	12-14	16-18	10	12	12	12-14
55 mph	Under 750	6-8	10-12	6	6-8	6-8	6-8
	750-1500	10-12	12-16	**	6-8	10-12	10-12
	1500-6000	12-14	16-18		10	10-12	12-14
	Over 6000	14-16	16-20*		10-12	12-14	14-16
60 mph	Under 750	10-12	12-16		6-8	8-10	10
	750-1500	12-16	16-20*		8-10	10-12	12-14
	1500-6000	16-18	20-24*		10-12	12-14	16
	Over 6000	18-20*	22-28*		12-14	16	16-18
65 mph	Under 750	12	12-16		6-8	10	10
	750-1500	16	18-22*		8-10	12	12-14
	1500-6000	18-20*	22-26*		10-12	14-16	16-18
	Over 6000	18-22*	24-28*		14-16	16-18	18

* Clear zones may be limited to 18 ft for practicality.
 ** See procedure in Section 38-3.02(b).

- Notes:
1. All distances are measured from the edge of the traveled way.
 2. For clear zones, the "ADT" will be the total ADT on two-way roadways and the directional ADT on one-way roadways (e.g., interchange ramps and one roadway of a divided highway). Traffic volumes will be the expected traffic volume through the work zone.
 3. The values for "back slopes" only apply to a section where the toe of the back slope is adjacent to the shoulder. See Figure 38-3B(d). For sections with roadside ditches, see Section 38-3.03.
 4. Approach posted speed limit prior to the work zone.

**WORK ZONE CLEAR ZONE DISTANCES
 (US Customary)**

Figure 55-4.B

Approach Posted Speed Limit ⁴	ADT	Front Slopes		Back Slopes			
		1:6 or Flatter	1:5 to 1:4	1:3	1:3	1:5 to 1:4	1:6 or Flatter
Work Zone Clear Zone Distances (m)							
35 mph or less	Under 750	1.5-2.0	1.5-2.0		1.5-2.0	1.5-2.0	1.5-2.0
	750-1500	2.0-2.5	2.5-3.0		2.0-2.5	2.0-2.5	2.0-2.5
	1500-6000	2.5-3.0	3.0		2.5-3.0	2.5-3.0	2.5-3.0
	Over 6000	3.0	3.0-3.5		3.0	3.0	3.0
35 - 50 mph	Under 750	2.0-2.5	2.5-3.0		1.5-2.0	1.5-2.0	2.0-2.5
	750-1500	3.0	3.0-4.0		2.0-2.5	2.5-3.0	3.0
	1500-6000	3.0-3.5	4.0-5.0		2.5-3.0	3.0	3.0-3.5
	Over 6000	4.0	4.5-5.5		3.0	3.5-4.0	4.0
55 mph	Under 750	2.5-3.0	3.0-3.5		1.5-2.0	2.0-2.5	2.0-2.5
	750-1500	3.0-3.5	4.0-4.5	**	2.0-2.5	3.0	3.0-3.5
	1500-6000	4.0	4.5-5.5		3.0	3.0-3.5	4.0
	Over 6000	4.0-4.5	5.0-6.0*		3.0-3.5	4.0	4.0-4.5
60 mph	Under 750	3.0-3.5	4.0-4.5		2.0-2.5	2.5-3.0	3.0
	750-1500	4.0-4.5	5.0-6.0*		2.5-3.0	3.0-3.5	4.0
	1500-6000	5.0-5.5	6.0-7.5*		3.0-3.5	3.5-4.0	4.5-5.0
	Over 6000	5.5-6.0*	7.0-8.5*		4.0	4.5-5.0	5.0-5.5
65 mph	Under 750	3.5-4.0	4.0-5.0		2.0-2.5	3.0	3.0
	750-1500	4.5-5.0	5.5-7.0*		2.5-3.0	3.5-4.0	4.0
	1500-6000	5.5-6.0*	6.5-8.0*		3.0-4.0	4.0-4.5	5.0-5.5
	Over 6000	5.5-6.5*	7.0-8.5*		4.0-4.5	5.0-5.5	5.5

* Clear zones may be limited to 5.5 m for practicality.

** See procedure in Section 38-3.02(b).

- Notes:
1. All distances are measured from the edge of the traveled way.
 2. For clear zones, the "ADT" will be the total ADT on two-way roadways and the directional ADT on one-way roadways (e.g., interchange ramps and one roadway of a divided highway). Traffic volumes will be the expected traffic volume through the work zone.
 3. The values for "back slopes" only apply to a section where the toe of the back slope is adjacent to the shoulder. See Figure 38-3B(d). For sections with roadside ditches, see Section 38-3.03.
 4. Approach posted speed limit prior to the work zone.

**WORK ZONE CLEAR ZONE DISTANCES
(Metric)**

Figure 55-4.B

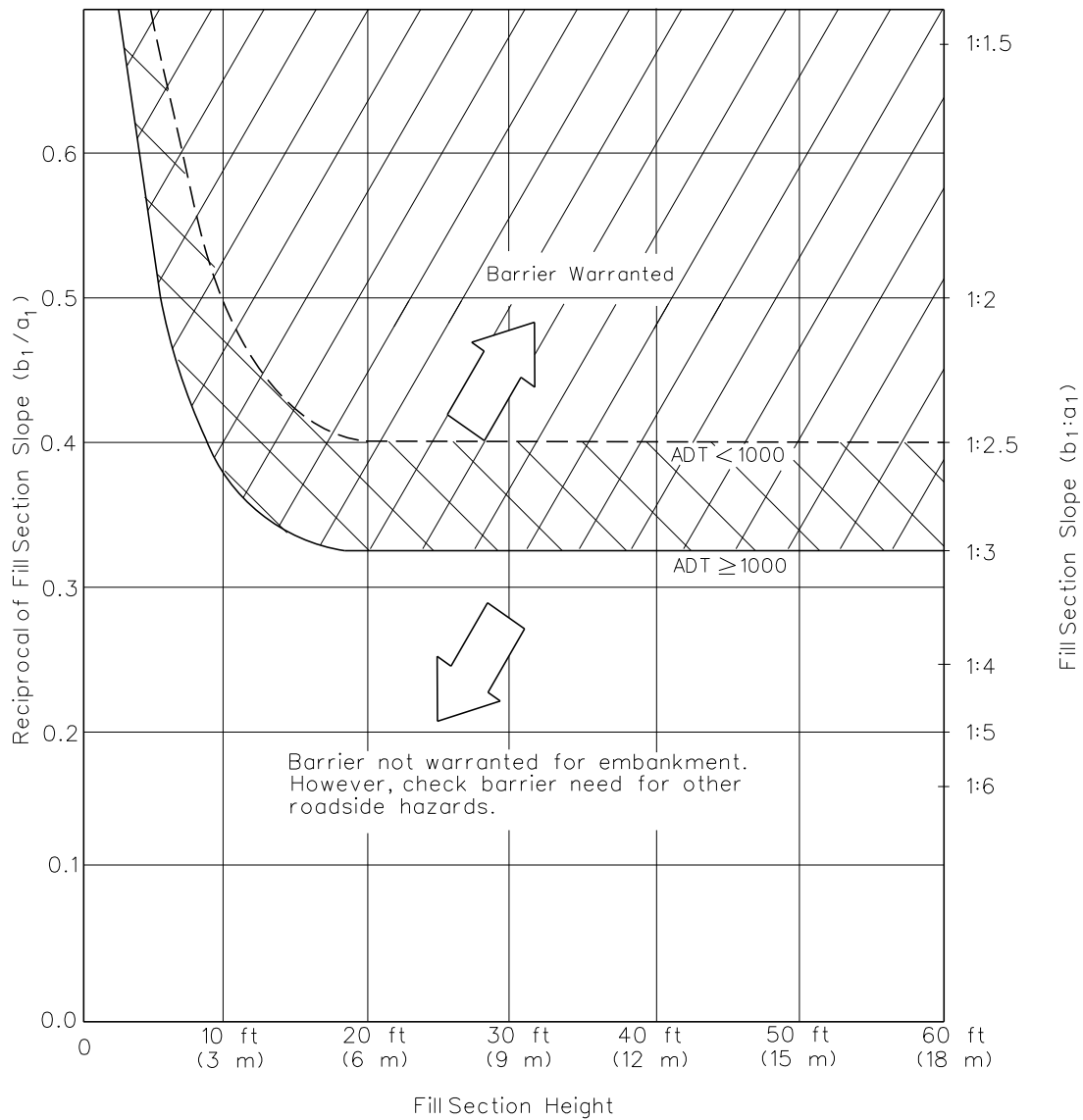

Note: Points which fall on the lines do not warrant a barrier.

**BARRIER WARRANTS FOR EMBANKMENTS
(Work Zones)**

Figure 55-4.C

5. Openings. Avoid openings in the barriers. Where openings are necessary, provide a NCHRP Report 350 approved end treatment at the barrier ends and proper signing.
6. Sand Barrels. Sand barrel arrays for temporary installations are the same as for permanent installations, except for the shielding of the hazard. Permanent sand barrel installations require a minimum 30 in (750 mm) offset between the hazard and the outside edge of the sand barrel array. For temporary installations, this distance can be reduced to 15 in (375 mm) where a greater offset would cause unacceptable interference with traffic. The preferable alternative is to use an attenuator system.

55-5 WORK ZONE TRAFFIC CONTROL DEVICES

The proper use of traffic control devices is critical to both public and worker safety and has been proven to significantly reduce crashes in work zones. The district Bureau of Operations will be responsible for the selection and design of traffic control devices. This section provides supplemental information on these devices and presents specific Department policies and procedures.

55-5.01 Highway Signs

55-5.01(a) General

In construction zones, regulatory signs are used to temporarily override an existing mandate or prohibition (e.g., reduced speed limit). Warning signs are used in advance of the construction area to indicate potentially hazardous conditions, and guide signs are used at various locations to inform drivers of detour routes, destinations, and points of interest.

In general, the *Highway Standards*, the *Standard Specifications*, and Part 6 of the *Illinois Manual of Uniform Traffic Control Devices* (ILMUTCD) provide the Department's criteria for the design, application, and placement of these signs in construction zones. In addition, the designer should review the applicable sections for permanent signs in Chapter 57 of the *BDE Manual*, the Bureau of Operation's *Policies and Procedures Manual*, and the *ILMUTCD*.

55-5.01(b) Speed Limit Signing

Signs are used to alert the traveling public of the speed limit within a work zone. The signs must comply with *the Highway Standards* for the work zone speed limit to be enforceable. The Work Zone Speed Limit Sign is the regulatory sign that is used to establish the speed limit in a construction or maintenance zone, as well as legally establish the zone for enforcement and fines. Use the Bureau of Operations "Policy on Establishing and Posting Speed Limits on the State Highway System" to establish speed limits in work zones.

The work zone speed limit will be determined based on the work zone design speed, traffic volumes, construction work type, geometrics, project length, etc. Where there is no lane closure or apparent hazard, maintain the existing speed limit.

See the *Standard Specifications* and *Highway Standards* for details on sign placement.

55-5.01(c) Guide Signs

The references in Section 57-1.02 provide the Department's criteria for the design, application, and placement of guide signs. The following provides supplemental information on the use of guide signs in construction zones:

1. Panel Signs. Guide signs are typically warranted in construction zones and on alternative routes where temporary route changes are necessary. For example, the designer may consider using large panel signs or changeable message signs for ramp and lane closures (e.g., “Ramp 2A Closed, Use Ramp 2B,” “Ramp 4A Closed May 9”).
2. Other. Standard route markings, street name signs, special information signs, directional, and detour signs may also be warranted based on the particular work on the facility.

55-5.01(d) Portable Changeable Message Signs

Portable changeable message signs (PCMS) are very effective in communicating the construction zone information to the general public. The use of PCMS will be determined on a project-by-project basis based on road alignment, traffic routing, or other situations requiring advance warning and information.

PCMS can be an effective temporary traffic control device when used appropriately. However, PCMS should not replace any of the signing required by IDOT policy or the *ILMUTCD*. The positive effect of PCMS may be diminished if the device is overused. PCMS should not be employed when they do not add any value to the total traffic control plan.

For all facilities, the following are some typical applications where the PCMS device may be effectively used in construction zones:

- to provide advance notice of upcoming construction;
- where significant traffic queuing and delays are expected;
- where changes in road alignment or surface conditions are present;
- to provide advance notice of ramp, lane, or road closures;
- incident management;
- a change in construction activities (e.g., bridge beam placement, change in alignment);
- to notify or direct motorists to alternative routing; and
- to provide additional information on high-volume, urban projects.

Messages shown on PCMS signs should convey current conditions and as up to date information to the traveling public as possible, especially for incident management. On projects where numerous PCMS signs will be used, the designer should plan for locations and messages to be used on the signs. PCMS messages should be limited to two, with a maximum of three phases. PCMS messages must be carefully planned to be short, understandable, and have “news value” to the motorist. Do not provide information that is redundant to static signing.

PCMS signs are required to be remote programmable. Include provisions for monitoring and changing the messages as necessary to provide current information. Investigate new and emerging technologies for monitoring and changing the messages that can be done by computer in the district, field office, or from a remote location.

See the FHWA *Portable Changeable Message Sign Handbook* and the *ILMUTCD* for specific information on the placement, operation, acceptable messages, and acceptable abbreviations for PCMS.

55-5.01(e) Arrow Boards

In some construction areas, arrow boards are used to supplement conventional traffic control devices. They are used as directional information to assist in merging traffic. The *Highway Standards* and Part 6 of the *ILMUTCD* provide the Department's criteria for the placement, design, and application of arrow boards.

55-5.02 Channelization Devices

The *Highway Standards*, the *Standard Specifications*, and Part 6 of the *ILMUTCD* provide the Department's criteria for the selection, application, and placement of channelization devices. Part 6 of the *ILMUTCD* and the *Highway Standards* also illustrate several typical application diagrams for the use of these devices.

There are numerous types of channelization devices available, each having its specific application in construction operations (e.g., crossovers, runarounds, lane closures, road closures, two-lane, two-way operations). Avoid mixing devices, as it may be confusing to the driver. The following channelization devices are typically used by IDOT in construction zones:

1. Barricades:
 - a. Type I and Type II Barricades. Type I or Type II barricades may be used for channelization or to delineate a specific condition.
 - b. Type III Barricades. Types III barricades are used for road and lane closures.
 - c. Directional Barricades. Directional Barricades may only be used in merging and shifting tapers.
2. Drums. Drums are most commonly used in a linear series to channelize traffic.
3. Cones. Traffic cones are channelization devices used only during daylight hours.
4. Tubular Markers/Vertical Panels. These devices are used to channelize traffic, to divide opposing lanes of traffic at posted speeds of 40 mph or less, or in lieu of drums where space is limited and speeds are 40 mph or less. Tubular markers and vertical panels have less visible area than other devices. Therefore, only use these devices where space restrictions do not allow for the use of more visible devices.
5. Temporary Traffic Barriers. Only use temporary traffic barriers where positive protection is desired; do not use based on channelization needs. If used, locate temporary traffic barrier behind and in conjunction with other supporting channelization devices,

delineators, and/or pavement markings. Section 55-4.02(b) provides information on the application and placement of temporary traffic barrier. Delineators, reflectors, and steady-burning lamps may be required by the *Highway Standards* or *Standard Specifications*.

6. **Delineators**. Delineators provide retroreflection from headlights and are supplemental devices commonly used to indicate the roadway alignment and the intended path through the construction zone.

These channelization devices are used extensively in work zones to warn drivers of work activities in or near the traveled way, to protect workers in the area, and to guide drivers and pedestrians safely through and around the work zone. Because each construction project differs, the selection, application, and location of these devices should be determined on a project-by-project basis.

55-5.03 Pavement Markings

The *Highway Standards* and Part 6 of the *ILMUTCD* provide the Department's criteria for the selection, application, and placement of pavement markings in work zones. The *Standard Specifications* provide additional information on pavement markings. Also, review Section 57-3 for applicable information on permanent pavement markings. The following sections provide supplemental guidelines to these sources.

55-5.03(a) Types

The following types of pavement markings are typically used by IDOT in work zones:

1. **Temporary Paint**. Quick-drying paint is a low-cost, temporary pavement marking that may be used on construction projects. To improve reflectivity, glass beads are required. The Department does not normally allow the use of temporary paint markings on final pavement surfaces.
2. **Temporary Raised Pavement Markers**. In high-volume locations, the designer may consider using raised temporary pavement markers as a supplemental device to improve delineation through the work zone. Typical locations include lane lines, gore areas, and other areas where there are changes in the alignment (e.g., lane closures, lane shifts). For lane lines, temporary raised pavement markers are placed mid-point in the gap (i.e., every 40 feet (12 m)). For tapers, gore markings, lane transitions, etc., space the raised markers at 20-ft (6 m) intervals. Temporary raised pavement markers must be removed prior to placing of the next pavement course.
3. **Temporary Pavement Marking Tape**. Temporary pavement marking tape is an excellent material choice where there are changes to the traffic pattern during construction (e.g., lane shifts, crossover switches). Temporary tape can be easily and quickly installed and, when necessary, easily removed. One disadvantage is that this tape tends to move

and/or breakup under heavy traffic volumes. Black tape is also available to temporarily remove lane lines. Wet reflective tape should be considered to improve guidance in long term work zones, poorly lit locations, and high volume areas.

4. Thermoplastic Markings. Thermoplastic markings are generally used in construction zones only if traffic volumes are high and the traffic pattern will be in place for a long duration (e.g., over one year).
5. Temporary Rumble Strips. Temporary rumble strips are used on high-speed, stop conditions to warn motorists of the impending change. The Highway Standards illustrate the typical layout for temporary rumble strips with a lane closure.

55-5.03(b) Application

The application of pavement markings in work zones depends on facility type, project duration, project length, and anticipated traffic volume. The *Standard Specifications* provide the criteria for the use of pavement markings in work zones.

55-5.04 Traffic Signals

55-5.04(a) Location

The use of temporary traffic signals in work zones will be determined on a project-by-project basis. Use the warrant criteria for permanent installations in Section 57-4 of the *BDE Manual* to assist in determining if a temporary traffic signal is warranted. However, use the actual traffic volumes expected during construction for the warrant analysis. Common locations where temporary signal installations may be used include:

- intersections where an existing signal must be maintained,
- existing non-signalized intersections and driveways where construction patterns and volumes now warrant a signal,
- at a temporary haul road or other temporary access points, and
- at crossroad/ramp intersections where there is an increase in traffic or there is a decrease in capacity due to the construction.

Temporary signals are required at long-term, one-lane, two-way traffic operations (e.g., stage bridge construction).

55-5.04(b) Application

Consider the following:

1. **Design.** Determine the impacts a construction activity has on existing signal operations and attempt to maximize the level-of-service. For example, consider:
 - re-timing or re-phasing the signal to compensate for changes in traffic volume, mix, or patterns and for changes in lane designations or intersection approach geometrics; or
 - physically relocating poles or adjusting signal heads to maintain compliance with the ILMUTCD.

Section 57-4 and Part 4 of the *ILMUTCD* provide design information on traffic signals.
2. **Bridges.** The Highway Standards require a temporary signal installation for a bridge lane closure. However, in some situations, the use of a flagger may be more cost effective.
3. **Plan Sheets.** Show all temporary signal installations on the Stages of Construction and Traffic Control Sheets.

55-5.05 Highway Lighting and Nighttime Construction

55-5.05(a) Types

The designer should maintain existing overhead lighting and, on a case-by-case basis, consider the need for supplemental roadway lighting at potentially hazardous sites within the work area.

Give special consideration to lighting of the traveled way during construction. Construction activities present unexpected road geometry, alignment, and hazards to the motoring public. The designer should maintain existing overhead lighting, and consider the need for supplemental roadway lighting at potentially hazardous sites within the work area.

The following lighting devices are used in construction areas:

- hazard identification beacons,
- steady-burning warning lamps,
- flashing warning lights,
- floodlights, and
- conventional highway lighting.

55-5.05(b) Warrants

Hazard identification beacons and warning lights are typically used to supplement signs, barriers, and channelization devices and emphasize specific signs, hazard areas, and the desired travel path. The warrants for these lighting devices should meet the criteria in Part 6 of the *ILMUTCD* and the *Highway Standards*.

For conventional highway lighting, the need for temporary lighting will be determined on a project-by-project basis. Maintain the existing highway illumination on all projects unless discontinuance of the highway illumination is specifically permitted. Review the warrants presented in Chapter 56 for permanent highway lighting to assist in determining the need for temporary lighting. Consider the use of temporary lighting at construction areas with the following characteristics:

- high-traffic volumes;
- high-traffic speeds;
- heavy queuing or congestion;
- areas with complicated traffic maneuvers (e.g., freeway crossovers, intersections); and
- other areas where hazardous locations may exist.

If existing light standards are removed or shut off during construction, consider providing temporary lighting until permanent light standards are reinstalled. In construction areas, the Department typically uses high-pressure sodium lamps mounted on temporary wood posts. However, the designer may wish to consider using portable lighting as an option. Chapter 56 provides additional information on the design of highway lighting.

55-5.05(c) Lighting for Nighttime Construction

Night construction presents additional challenges to both the contractor and the motoring public. The contractor needs adequate light to perform the work in a safe and efficient manner, and the motoring public requires additional guidance to safely transition the night work zone environment. As well, the motoring public must be protected from glare. Floodlights or other supplemental lighting may be used to illuminate the work area during night operations (e.g., flagger stations, equipment crossings, areas requiring supplemental lighting) and are the responsibility of the Contractor. See the BDE special provision “Nighttime Work Zone Lighting” for guidance.

55-6 ENFORCEMENT

Enforcement is one of the four “E”s of highway safety, along with engineering, education, and emergency medical services. Enforcement plays a unique and critical role in relation to work zones. Presence of law enforcement appropriately deployed in the vicinity of a construction project has proven effective in gaining compliance with posted speed limits to enhance work zone safety.

55-6.01 Implementation of Enforcement

Law enforcement patrols for work zones can be provided in three different ways: the Hire-back Program, Photo Speed Enforcement, or through the Annual Highway Program.

55-6.01(a) Hire-back of Police Patrols

Hire-back hours are used for active projects. At the beginning of the construction season, a distribution of work hours is allotted to each IDOT district based upon the number of active projects and the number of hire-back hours available. Schedules are then made at the IDOT district level for the most effective use of the officers. One to five work projects are patrolled by officers during a duty shift in an effort to increase their visibility and effect. The work hours are gathered from each IDOT district each fiscal year and distributed by the Bureau of Operations. Districts may request additional work-hours if justified for special circumstances.

55-6.01(b) Photo Speed Enforcement

Photo speed enforcement may be planned for inclusion in a project or added to existing projects. Photo speed enforcement vans are deployed in work zones where workers are present to gain compliance with posted speed limits and enhance safety. The Bureau of Safety Engineering allocates hours to ISP Districts based upon van availability and IDOT construction projects that are conducive to deployment of the vans. ISP Districts then coordinate with appropriate IDOT districts and the Bureau of Safety Engineering to schedule and execute deployments of the vans at the planned locations. The same speeding fines apply to photo speed enforcement as any other work zone violation.

55-6.01(c) Annual Highway Program

Enforcement may be planned for a project in Phases I and II. This program allows project planners and designers to designate enforcement for a specific project during the design stage. Projects that should consider use of planned enforcement include complex work zones with high speeds or high traffic volumes, especially those that may benefit from presence of enforcement over an extended period of time or that may use an excessive amount of hire-back funds.

Designers should indicate the need for presence of law enforcement as part of the Phase I and Phase II process in developing the project Transportation Management Plan. Designers should

coordinate with Construction, Operations, and Programming Engineers to include this cost as an additional project expense in the highway program, as opposed to using annual allocation of hire-back hours, if it is warranted in order to ensure that dedicated law enforcement is provided in the work zone. Unique contracts are required for each project using enforcement through annual highway program funding. In all cases, the ISP are paid-in-full prior to assignment of officers.

55-6.02 Fines

Current Illinois law supports increased fines for speeding in work zones. First offense results in a mandatory court appearance and a minimum \$375 fine. A second offense within two years results in a minimum \$1,000 fine and a 90-day suspension. These fines include a surcharge amount that is deposited into the Transportation Safety Highway Hire-back Fund. For a \$375 fine, \$125 dollars is deposited into this fund. For a \$1,000 fine, \$250 dollars is deposited into this fund.

Advance warning signs are also required to warn drivers that the \$375 minimum fine is in effect. Work zone fines are dependent upon the presence of work zone speed limit signs and not the presence of workers. These fines can also be assessed for urban projects with the proper signage.

55-7 REFERENCES

1. *Standard Specifications for Road and Bridge Construction*, IDOT.
2. *Highway Standards*, IDOT.
3. *Traffic Policies and Procedures Manual*, Bureau of Operations, IDOT, 1988.
4. *Illinois Manual on the Uniform Traffic Control Devices (ILMUTCD)*, IDOT.
5. *A Policy on Geometric Design of Highways and Streets*, AASHTO, 2004.
6. *Roadside Design Guide*, AASHTO, 2006.
7. *Highway Capacity Manual 2010*, Transportation Research Board, 2010.
8. *Policy on Establishing and Posting Speed Limits on the State Highway System*, Bureau of Operations, IDOT, 2002.

