

Chapter Sixteen

REST AREAS/WEIGH STATIONS

BUREAU OF DESIGN AND ENVIRONMENT MANUAL

Chapter Sixteen
REST AREAS/WEIGH STATIONS

Table of Contents

<u>Section</u>	<u>Page</u>
16-1 REST AREAS	16-1.1
16-1.01 General.....	16-1.1
16-1.02 Rest Area Committee (RAC)	16-1.1
16-1.03 Departmental Responsibilities	16-1.2
16-1.04 Interstate Rest Areas.....	16-1.2
16-1.04(a) Spacing	16-1.2
16-1.04(b) Site Selection	16-1.2
16-1.05 Interstate Design	16-1.5
16-1.05(a) Vehicle Capture Rates	16-1.5
16-1.05(b) Design Elements.....	16-1.9
16-1.05(c) Entrance and Exit Ramp Terminals	16-1.9
16-1.05(d) Vehicle Parking Requirements.....	16-1.9
16-1.05(e) Pavement/Shoulder Design	16-1.10
16-1.05(f) Comfort Station	16-1.15
16-1.05(g) Other Amenities	16-1.19
16-1.05(h) Accessibility Requirements	16-1.20
16-1.05(i) Utilities	16-1.20
16-1.05(j) Outdoor Electrical and Mechanical Equipment	16-1.21
16-1.05(k) Landscaping.....	16-1.21
16-1.06 Rest Stops.....	16-1.21
16-1.06(a) General	16-1.21
16-1.06(b) Site Selection	16-1.22
16-1.06(c) Design Guides	16-1.22
16-1.06(d) Access Control/Right-of-Way.....	16-1.22
16-2 WEIGH STATIONS.....	16-2.1
16-2.01 General.....	16-2.1
16-2.02 Weigh Station Committee.....	16-2.1
16-2.03 Interstate Weigh Stations	16-2.2
16-2.03(a) Site Selection Criteria	16-2.2
16-2.03(b) Planning	16-2.2
16-2.04 Interstate Design Criteria.....	16-2.3

Table of Contents

(Continued)

<u>Section</u>		<u>Page</u>
	16-2.04(a) General	16-2.3
	16-2.04(b) Weigh-in-Motion	16-2.7
	16-2.04(c) Storage Requirements	16-2.7
	16-2.04(d) Entrance and Exit Terminals	16-2.10
	16-2.04(e) Detention Parking Requirements	16-2.10
	16-2.04(f) Pavement Design.....	16-2.10
	16-2.04(g) Vehicle Inspection Pit.....	16-2.10
	16-2.04(h) Conversion of Static Scale Facility to Weigh-in-Motion..	16-2.12
	16-2.04(i) Intelligent Transportation Systems (ITS).....	16-2.12
16-2.05	Arterial Weigh Stations	16-2.12
	16-2.05(a) General	16-2.12
	16-2.05(b) Site Selection	16-2.13
	16-2.05(c) Design Guides	16-2.13
16-3	CONTRACT PLANNING AND COORDINATION	16-3.1
16-3.01	General.....	16-3.1
16-3.02	Scope	16-3.1
	16-3.02(a) Division of Work	16-3.1
	16-3.02(b) Coordination of Scope	16-3.2
16-4	REFERENCES.....	16-4.1

Chapter Sixteen

REST AREAS/WEIGH STATIONS

16-1 REST AREAS

16-1.01 General

Rest areas are an essential element of the complete highway system. They are provided for the safety and convenience of the traveling public. A rest area provides an oasis for weary travelers to relax and refresh from the rigors of highway travel. A comfort station is provided to accommodate the basic needs of the traveling public. Multi-use land is also provided for picnic tables and limited recreational activities. Rest stops for two-lane highways are discussed in Section 16-1.06.

Welcome centers are rest areas located at port-of-entry routes that also provide a full range of amenities. Welcome centers are staffed to provide assistance to travelers regarding directions, lodging arrangements, automotive services, food services, and many other activities. Welcome centers also promote local tourist attractions. Tourist information centers are rest areas that provide amenities similar to welcome centers but are located on interior routes and generally serve a specific tourist area.

16-1.02 Rest Area Committee (RAC)

The RAC is comprised of members of the Division of Highways and directs the rest area program to ensure that the Department's objectives are met. The Committee is co-chaired by the Deputy Director of Operations and Administration and the Deputy Director of Program Development. The responsibilities and Committee objectives are as follows:

1. Bureau of Operations. This Bureau is responsible for maintaining the rest areas, comfort stations, signing, and traffic operations.
2. Bureau of Design and Environment. The BDE will have one representative on the Committee.
3. District. One representative from the district will serve on the Committee, and the district is responsible for providing the environmental survey of the site and the geometric design of the rest area.
4. Committee. The Committee's responsibilities include:
 - reviewing and evaluating all applicable guidelines, policies, and procedures for the location and design of a rest area facility;

- establishing priority projects and coordinating the construction program; and
- recommending corrective rehabilitation treatments as appropriate.

16-1.03 Departmental Responsibilities

The recommended actions of the RAC are carried out by the districts, BDE, and Bureau of Operations. Their responsibilities are noted in Figure 16-1.A.

16-1.04 Interstate Rest Areas

16-1.04(a) Spacing

Select and acquire the site for the rest area concurrently with the acquisition of the freeway right-of-way. Use a one-hour driving time to determine the average spacing between rest areas. However, many factors influence the final location of the site.

16-1.04(b) Site Selection

Rest areas should be developed as part of a comprehensive program that considers:

- the attractiveness of the location,
- the site's topography,
- the distance from other rest areas,
- the distance between interchanges, and
- the availability of water and utilities.

Consider the following additional information during the site selection process:

1. Needs Assessment. The RAC, in cooperation with the district, will make the determination that a rest area is to be constructed within certain limits of a freeway corridor.
2. Site Investigation and Prioritization. Representatives of the Committee and the district will investigate potential sites and prioritize the sites using the form illustrated in Figure 16-1.B. Site selection basically considers the scenic quality of the area, access to the area, and the site's adaptability to development including available utilities.
3. Residential and Industrial Areas. Desirably, do not locate rest areas near residential or industrial areas due to noise and fumes. New rest areas or improvements to an existing rest area may be considered a Type I project for noise and consequently require a noise analysis. Traffic noise analyses shall be conducted in accordance with Section 26-6 "Noise Analyses" of this BDE Manual. The *IDOT Highway Traffic Noise Assessment Manual* has been prepared to provide guidance on how to implement the policy for IDOT

projects or projects being reviewed by IDOT. The guidance manual provides information to be included in the environmental documentation.

Bureau of Design and Environment	
<ul style="list-style-type: none"> • Establish Building/Grounds Policy • Propose Site Locations • Select Rest Area Names • Consultant Selection Rating • Coordinate with District on Building Design • Review and Comment on Construction Plans • Participate in District/Consultant Meetings • Develop Site Lighting Plan 	
District	
<ul style="list-style-type: none"> • Review Site Locations • Approve Rest Area Names • Develop Conceptual Layouts/Review • Prepare Environmental and Design Reports • Request Environmental Surveys • Early Coordination with Outside Agencies • Review Conceptual Layouts • Develop Rest Area Geometrics • Preliminary Design Approval • Hold Public Informational Meetings • Early Coordination with Outside Agencies • Apply for NPDES Permit • Prepare Roadway and Parking Lot Plans • Consultant Selection Rating • Coordinate Consultants on Building Design • Approve Final Design Plans • Coordinate with Capital Development Board for Building Plans 	<ul style="list-style-type: none"> • Coordinate with Department of Commerce and Community Affairs (DCCA) • Coordinate with the Department of Rehabilitation Services • Prepare Landscape Plans Including Appurtenances • Review and Approve Landscape Plans • Review Lighting Plans and Incorporate • Oversee Construction of Project • Coordinate with Bureau of Operations on Maintenance Contracts • Assure Maintenance Compliance to Department Standards • Administer Maintenance Contracts • Monitor Vending and Tourism Operations • Perform or Contract for Repairs
Bureau of Operations	
<ul style="list-style-type: none"> • Establish Building/Grounds Policy • Review Site Locations • Review and Comment on Geometric Designs • Review Roadway and Parking Lot Design • Develop Sign and Striping Policies • Coordinate with District on Signing and Striping Plan • Consultant Selection Rating • Coordinate with District on Building Design • Participate in District/Consultant Meetings & DCCA • Coordinate with Department of Rehabilitative Services on Vending Facilities • Review and Approve Construction Plans • Review and Approve Landscape Plans • Provide Policies and Procedures for Maintenance Operations & Standards • Coordinate with District on Maintenance Contracts • Provide for Testing of Water Plant Sewage Effluents when necessary • Provide for Repairs at Facilities • Conduct Annual Rest Area Evaluation Report 	

REST AREA COMMITTEE PARTICIPANTS AND RESPONSIBILITIES

Figure 16-1.A

Criteria	Alternatives				
	#1	#2	#3	#4	#5
A. Aesthetics					
1. Fits Topography					
2. View From Interstate					
3. View From Rest Area					
4. Landscaping Potential/Screening					
5. Natural Site Features/Existing Tree Cover					
B. Geometrics					
1. Adequacy Truck/R.V. Parking					
2. Adequacy Car Parking					
3. Expansion Potential					
4. Accessibility					
C. Use Areas					
1. R.V. Picnic Area					
2. Picnic Areas					
3. Sidewalks					
4. Playground					
5. Pet Walks					
6. Security					
D. Land Use Compatibility					
1. Adjacent Farmsteads/Subdivisions					
E. Environmental Control					
1. Hazmat					
2. Water Quality/Wetland					
3. Endangered Species					
4. Archaeology					
5. Air					
6. Noise					
7. Right-of-Way					
F. Distance From Commercial Enterprise					
1. Truck Stops					
G. Utilities					
1. Sewage					
2. Water					
3. Gas					
4. Electric					
H. Cost					
Totals					

Rank 1 -5
 1 - Lowest
 5 - Highest
 N/A - Indicates Not Applicable

EVALUATION CRITERIA FOR SITE SELECTION, LAYOUT, AND DESIGN OF INTERSTATE REST AREAS

Figure 16-1.B

4. Water and Sewer Needs. As practical, use a municipal service for the facility's water and sewer system. Recommend using municipal services to reduce operating costs. If access to a municipal system is unavailable, provide well water and an on-site waste disposal system. Contact the Illinois State Geological Survey for assistance in evaluating the water conditions of a proposed site. Also, contact local well driller/contractors for local history of water depths.
5. Right-of-Way Needs. Approximately 25 acres (10 ha) of right-of-way are necessary to accommodate each site.
6. Locations Near Interchanges. Where a rest area is located near a freeway interchange, provide a minimum distance of 3000 ft (1000 m) between the ramp gores of the rest area and the interchange. Provide a greater distance where a rest area ramp is near a major convergence or divergence.
7. Juxtaposition of Rest Areas. Locate rest areas on a freeway so that the rest area approaching on the right precedes the rest area on the opposite side of the freeway and separate them by at least 0.25 miles (400 m). Where rest areas are located closer than the desired distance, consider providing a fence or other physical barrier in the median to restrict crossover pedestrian traffic. Locate rest areas near median crossovers to allow maintenance operations to easily access both locations.
8. Entrance and Exit Ramps. Design rest area entrance and exit ramp terminals according to the typical design criteria used for interchange ramps. See Section 16-1.05(c).

Once a site has been selected, presented to the RAC, and inspected by representatives of the FHWA for preliminary approval, prepare a Phase I report and submit it to the BDE for obtaining FHWA approval.

16-1.05 Interstate Design

16-1.05(a) **Vehicle Capture Rates**

National studies indicate that approximately 10% of the total Average Daily Traffic (ADT) will enter a rest area. A study conducted by the Department concluded that 9% of passenger cars and 15% of trucks in the approaching traffic stream will enter a rest area. The criteria for estimating the number and type of vehicles that will enter a rest area based on the Average Daily Traffic (ADT) is illustrated in Figure 16-1.C. The criteria for determining the number of persons projected to use the rest area, the anticipated demand for water, and the type of rest room facilities that should be provided are illustrated in Figure 16-1.D.

Route _____ Rest Area _____ NSEW-Bound _____

County _____ Analyst _____ Date _____

Two-Way ADT _____ (Current/Projected) Year _____

x 0.60 Directional Distribution (1 Way ADT) _____

x 0.11 Design Hourly Volume (30th Max. Hr.) DHV

Parking Requirements	
Trucks	Passenger Cars
% Trucks _____ x DHV = _____ x 0.15 Entering Veh. = _____ x 0.50 Dwell Time/Turnover <input type="text"/> Min. Required Truck Stalls (One Side Only)	% P. Cars _____ x DHV = _____ x 0.09 Entering Veh. = _____ x 0.34 Dwell Time/Turnover <input type="text"/> Min. Required P. Car Stalls (One Side Only)*

Notes:

- *1. Passenger car stall requirements should be increased 25% for welcome centers.
- 2. Provide one (1) handicap stall per 25 passenger cars in the passenger car parking area.
- 3. Provide one (1) handicap stall per 25 trucks in the truck parking area.
- 4. See Section 16-1.05(d) for maximum number of vehicle parking stalls.

Picnic Tables	Litter Receptacles
DHV x 0.008 = <input type="text"/> (Generally, 33% are sheltered.)	DHV x 0.0008 = <input type="text"/>

Determination of Design Guidelines for Rest Area Parking Requirements

- Enter with two-way **ADT** for current or projected year.
- **Directional Distribution** — A 60/40 distribution is a typical split on the Interstate highway system.
- **Design Hourly Volume** — The DHV represents the 30th maximum hourly volume of the year (30 HV). In this case, it represents the vehicles on the mainline that approach a rest area in one hour. Typical conversion of ADT to DHV on the Illinois Interstate system is 11% as indicated in *Traffic Characteristics on Illinois Highways — Bi-Annual Report OPP*.
- **Trucks/Cars as % of Traffic** — Enter actual truck and passenger car percentages of the appropriate highway section and multiply by the DHV.
- **Percent of Entering Vehicles** — Typically, 15% of the trucks and 9% of the passenger cars enter the rest area.
- **Dwell Time** — Assume a dwell time of 15 minutes for trucks and 10 minutes for passenger cars. A factor of 2 is used to convert to 30 minutes (0.50 hour) for trucks and 20 minutes (0.34 hour) for passenger cars.

DESIGN GUIDELINES FOR INTERSTATE REST AREA PARKING REQUIREMENTS

Figure 16-1.C

Route _____ Rest Area _____ Date _____

County _____ Analyst _____

Two-Way ADT (Current/Projected) Year _____

- x 0.60 Directional Distribution (One-Way ADT) _____
- x 0.11 Design Hour Volume (30th Max. Hr.) _____
- x 0.10 Vehicles Entering Rest Area Per Hr. _____
- x 2.0 Average Vehicle Occupancy _____
- x 0.85 Persons/Rest Room Usage = **P/RU** _____
- ÷ 60 Persons Per Minute _____
- * x 2.5 Gallons (9.5L) Per Person = **GPM (LPM)**
- x 60 Gallons (Liters) Per Hour = **GPH (LPH)**
- x 12 Gallons (Liters) Per Day = **GPH (LPD)**
(One Side Only)

Notes:

- *1. *Ensure that the momentary peak flow rate (GPM (LPM)) is twice the design flow rate or the total toilets and urinals times 5 GPM (19 LPM), whichever is less for a period of two hours.*
2. *Check water supply systems to determine the impact of momentary peaks.*
3. *Provide design usage at a pressure of 40 psi (275 kPa).*

Rest Room Amenities							
P/RU	Men				Women		
	Urinals	Toilets	W. Basins	H. Dryers	Toilets	W. Basins	H. Dryers
<250	4	2	2	2	6	2	2
>250	4	4	4	4	8	4	4
>500	6	4	4	6	10	4	6

Note: Values may be adjusted for site-specific percentages.

DESIGN GUIDELINES FOR INTERSTATE REST AREA USAGE AND WATER NEEDS

Figure 16-1.D

- Enter with **Two-Way ADT** for current or projected year.
- **Directional Distribution** — Use a 60/40 distribution, which is a typical split on the Interstate highway system.
- **Design Hourly Volume** — The DHV represents the 30th highest hourly volume of the year (30 HV). In this case, it represents the vehicles on the mainline that approach a rest area in one hour. Typical conversion of ADT to DHV on the Illinois Interstate system is 11% as indicated in *Traffic Characteristics on Illinois Highways — Bi-Annual Report OPP*.
- **Vehicles Entering Rest Area** — Typically, 15% of the trucks and 9% of the passenger cars will enter the rest area. Using a typical Interstate truck percentage of 28% and 72% for passenger cars, the capture rate of passing vehicles is a weighted average of 10%. On Interstate routes where the truck percentage is 45%, the weighted average is 16%. Various truck percentages can be interpolated to determine the weighted average.
- **Vehicle Occupancy** — Vehicle occupancy is determined to be 1.83 persons per vehicle; however, the weekend rate is 2.3. Use a weighted average of 2.0 for these calculations.
- **Persons/Rest Room Usage** — Of the people entering a rest area, 85% will utilize the rest rooms. A slightly higher percentage of men use the rest rooms than women, but the difference is not significant to warrant any difference in rest room conveniences.
- **Water Usage** — Use a value of 2.5 gallons (9.5 L) per person to determine the peak gallons (L) per minute rate (based on low-volume flush toilets and urinals). Provide for enough on-site water storage to handle peak traffic volumes.
- **Water Usage Per Day** — The multiplier of 12 is based on GPH (gallon per hour) (LPH, liters per hour) rate for two hours per day, 80% of GPH occurring for eight hours and 25% of GPH occurring for 14 hours. Hence, $GPD = (GPH) (2) + (0.8 GPH) (8) + (0.25 GPH) (14) = 11.9$ round to 12.
- Use the **P/RU** value in the table to determine the desirable rest room amenities.

DESIGN GUIDELINES FOR INTERSTATE REST AREA USAGE AND WATER NEEDS

Figure 16-1.D
(Continued)

16-1.05(b) Design Elements

Consider the following guidelines during the design of rest areas:

1. Buffer Zone. To enhance patron safety, locate the facility a minimum distance of 100 ft (30 m) away from the freeway to create a buffer zone to the nearest use area.
2. Parking. See Section 16-1.05(d) for information on vehicle parking requirements.
3. Internal Roadways. Design internal rest area roadways for a minimum speed of 20 mph (30 km/h) and a desirable speed of 25 mph (40 km/h).
4. Curbing. Curbing may be used on internal roadways to restrict illegal parking on the shoulder and to minimize vehicular encroachment.
5. Fencing. Fence the rest area right-of-way to prevent access to or from adjacent properties.

16-1.05(c) Entrance and Exit Ramp Terminals

Provide access to and from rest areas according to the typical ramp terminal designs presented in Chapter 37 and the *Highway Standards*. Also consider the following additional information on entrance and exit ramp terminals:

1. Exit Ramps. Design initial ramp curves for 50 mph (80 km/h) and limit superelevation to 6% maximum. Provide decision sight distance for the exit maneuver. Provide a deceleration distance of 600 ft (180 m) from the gore of the exit ramp to the car/truck divergence gore.
2. Entrance Ramps. Provide a minimum distance of 1200 ft (350 m) from the truck parking area to the gore nose on the entrance ramp. This distance typically will allow a truck to accelerate to an acceptable speed before entering the freeway. Adjust the acceleration distance where the ramp terminal is on a grade greater than 3% or where the freeway level of service is adversely affected by the truck's merging speed. See Section 37-6.02 for additional guidance.

16-1.05(d) Vehicle Parking Requirements

The annual growth of traffic on the Interstate highway system has created the demand to increase vehicle parking requirements for new and rehabilitated rest areas. The RAC has established that a facility should be maximized at 50 passenger car stalls and 40 truck stalls. Where site conditions restrict full compliance of the maximum requirements, apply the values obtained from Figure 16-1.C.

See Figures 16-1.E and 16-1.F for typical design layouts. Chapter 37 provides additional criteria. Typically, truck parking areas are located to the rear of a site. An exception to this

would be if the terrain or a scenic vista would be better served if passenger cars were located at the rear of a site. Within the car parking area, the through roadway width of 20 ft (6.0 m) is desired with diagonal parking generally on both sides of the roadway. Provide B-6.18 (B-15.45) curb and gutter within the vehicle parking area.

The truck parking area should typically provide a center aisle 30 ft (9.2 m) wide with 45-degree diagonal parking on both sides; however, 35-degree may be used in confined areas. See Figure 16-1.G for an example of the typical stall dimensions. Design exit aisles to be 28 ft (8.6 m) in width, minimum, with an adjacent B-9.18 (B-22.45) curb and gutter. Desirably, place an island in the truck parking area near the center walkway to the comfort station. This island may contain a telephone kiosk and picnic tables. Design ramp widths and roadway geometry to accommodate a WB-65 (WB-20) design vehicle assuming the Case I condition. Ramp widths are normally 16 ft (4.9 m) wide; however, increase this width to accommodate truck off-tracking when providing a curved alignment. See Section 36-2.03 for turning roadway widths that are also applicable to rest areas.

16-1.05(e) Pavement/Shoulder Design

Design the rest area exit and entrance ramps, roadways, shoulders, and parking areas according to Section 54-1.07. The concentration of heavy trucks braking on the ramps and inner roadways and the sharp turning maneuvers to enter parking stalls requires these facilities to be considered “high stress” locations. See Chapter 54 for guidelines on “high stress” pavement designs. Design ramps to handle overflow truck parking on shoulders (40,000 lbs (16,000 kg) plus for each truck).

Figure 16-1.H illustrates a typical ramp cross section with 1V:4H side slopes and pipe underdrains. In areas where curbing is desired to restrict trucks from parking on the shoulder, use a B-9.24 (B-22.60) curb and gutter. For truck parking areas, use a B-6.18 (B-22.45) curb and gutter with a 1 ft (300 mm) wide curb top. For car parking areas, use a B-6.18 (B-15.45) curb and gutter. Ramp all island noses for safety and ease of maintenance.

Because of the likelihood of vehicle off-tracking onto ramp shoulders, provide fully paved 8 ft (2.4 m) wide shoulders on the right and fully paved 4 ft (1.2 m) wide shoulders on the left. The transition (i.e., intersection of paved shoulders) between the rest area shoulder design and the freeway shoulder design will occur near the 1 ft (300 mm) stub of the ramp tapers.

Design ramp elements (e.g., superelevation, superelevation transitions, crossover crown) as indicated in Chapter 37.

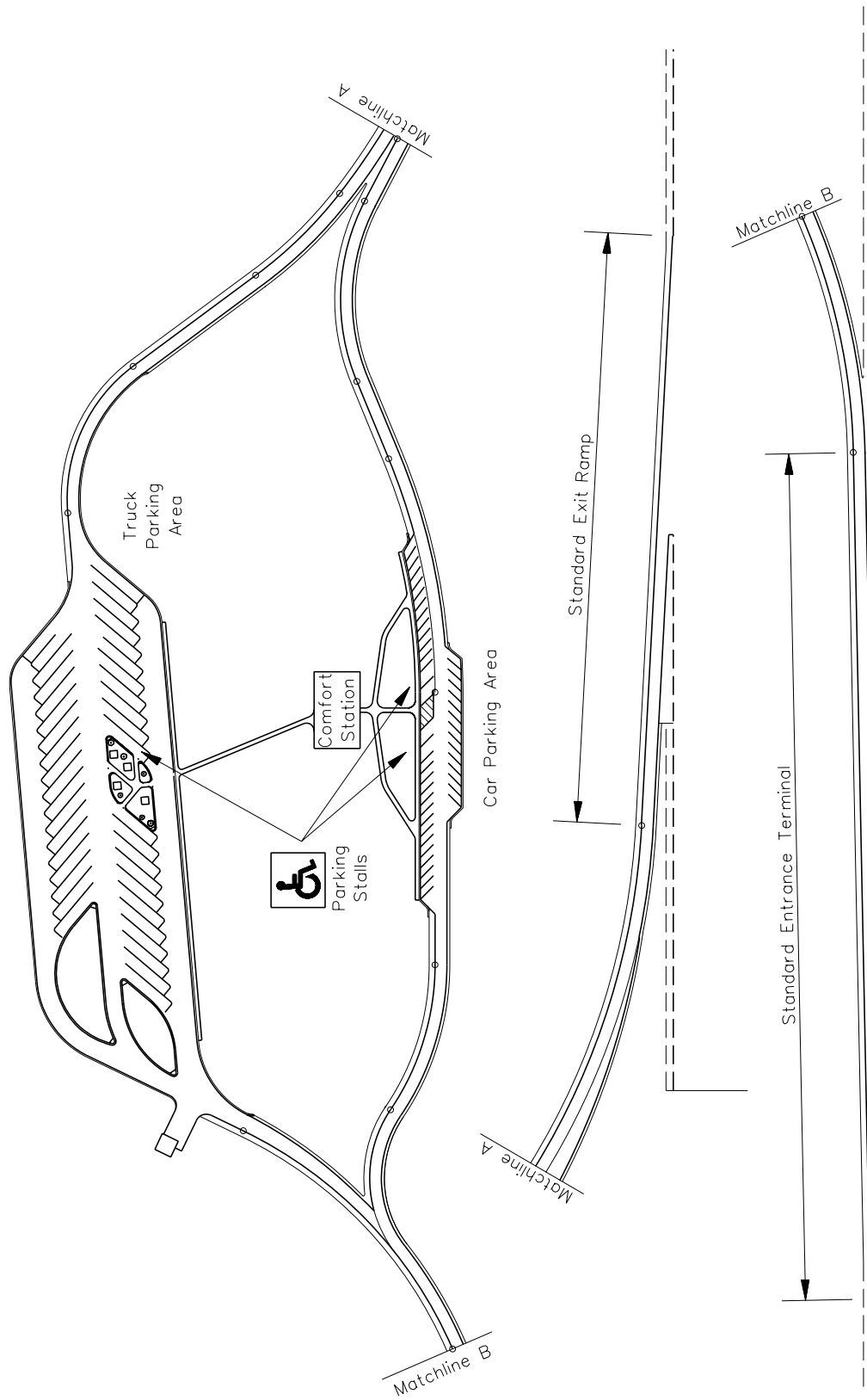

TYPICAL REST AREA DESIGN LAYOUT

Figure 16-1.E

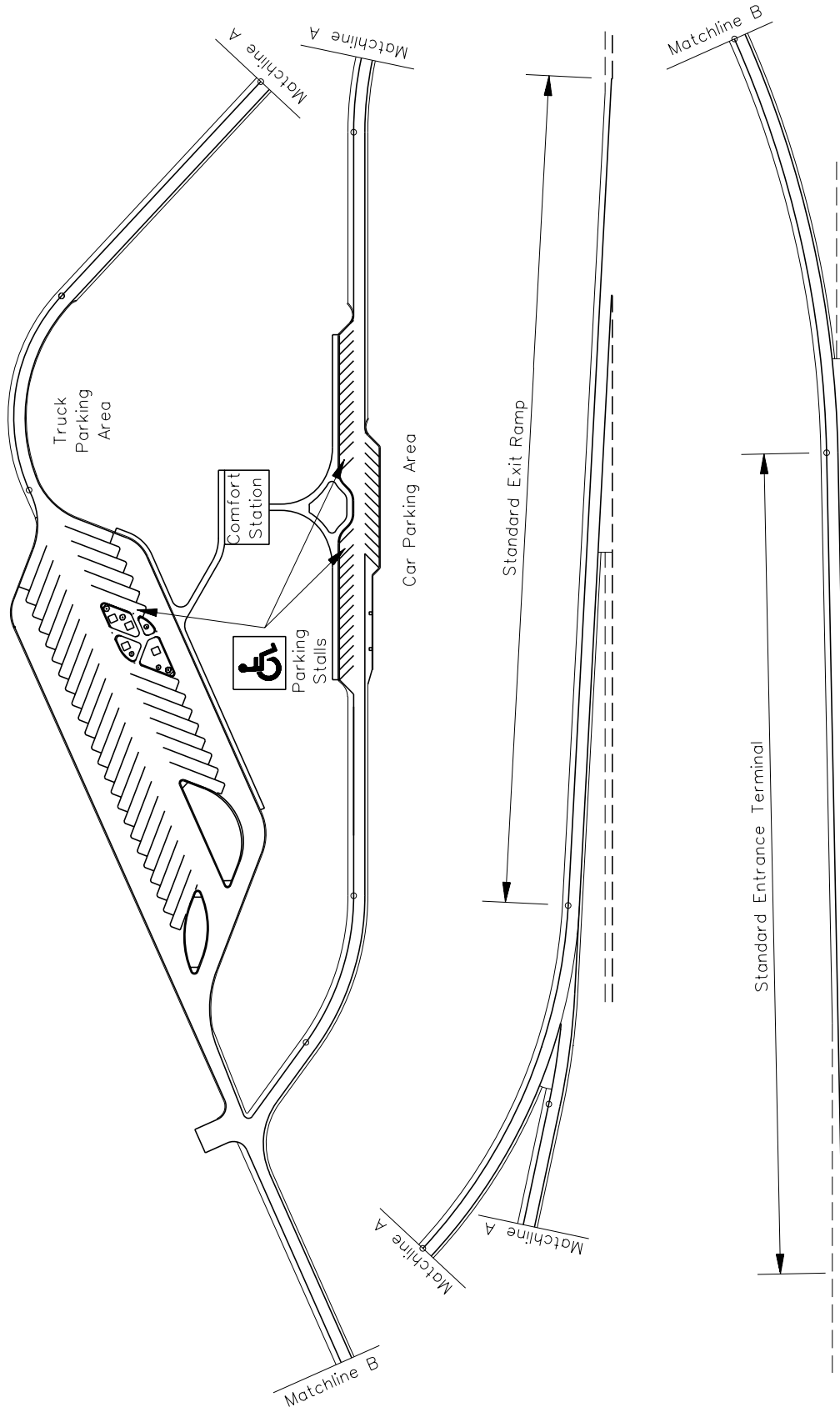

TYPICAL REST AREA DESIGN LAYOUT

Figure 16-1.F

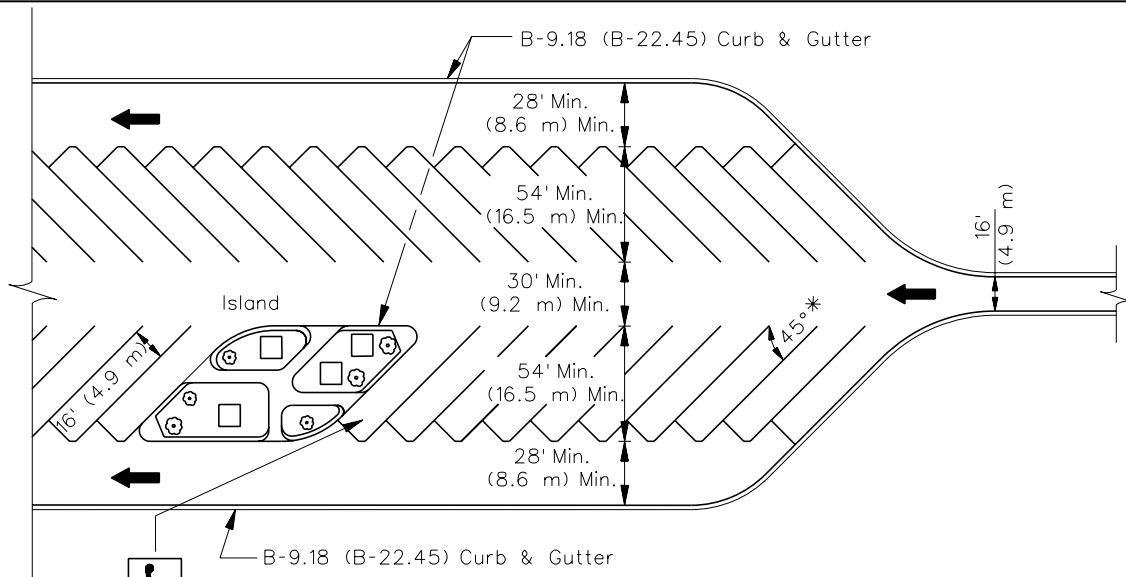

* Where 35° angle parking is provided, aisle widths may be reduced by 2ft (600 mm) and stall widths reduced by 1ft (300 mm).

TRUCKS

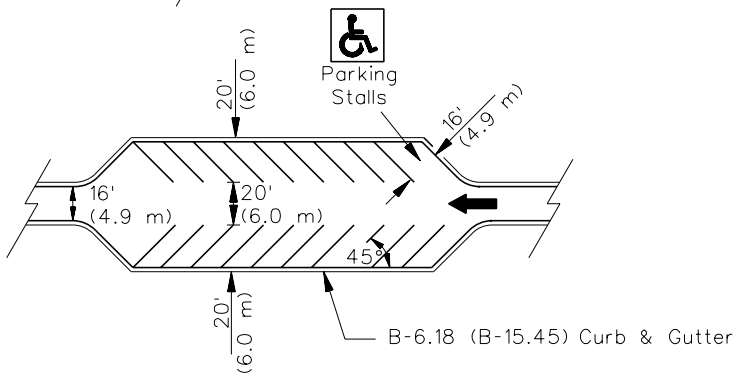
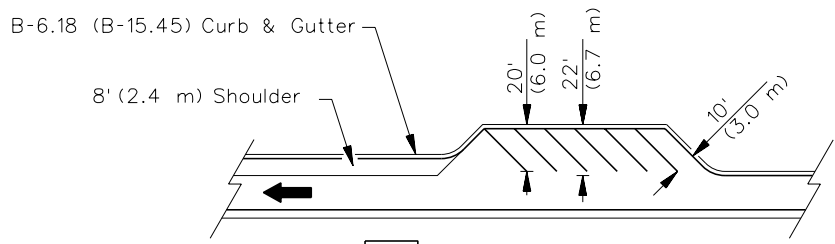

PASSENGER CARS

TYPICAL PARKING CONFIGURATION

Figure 16-1.G

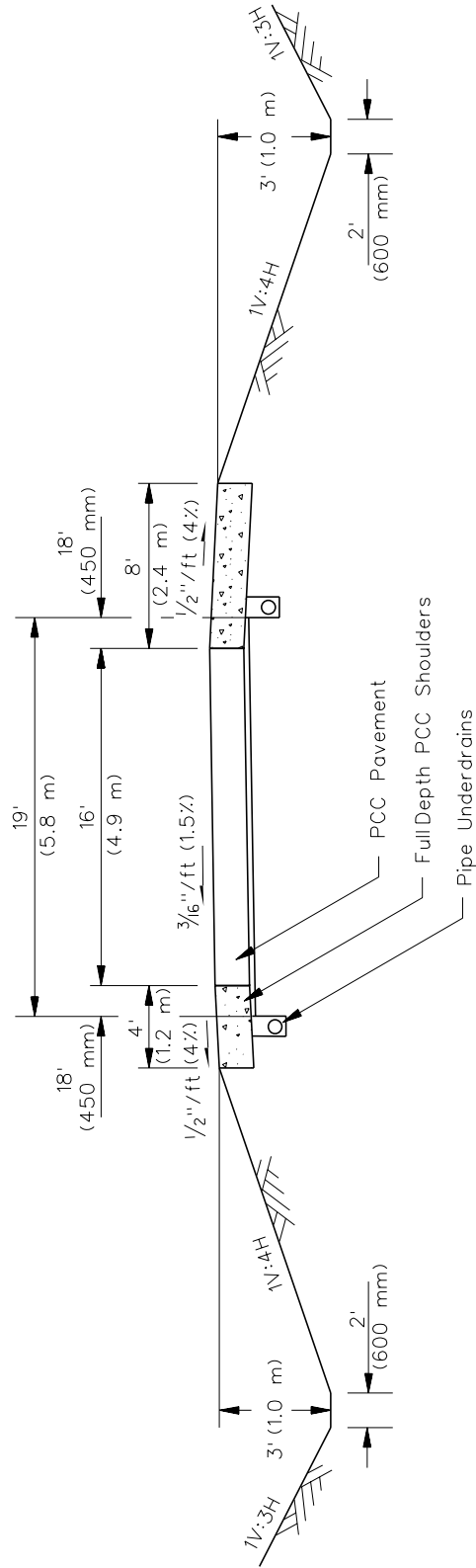

**RAMP CROSS SECTION
(Rest Areas)**

Figure 16-1.H

16-1.05(f) Comfort Station

Entranceways to comfort stations should provide an unobstructed walkway to the facility as well as a clear view into the lobby area. Elevated planters, walls, shrubs, and bushes should not obscure the view of the approaching patron. The open view also allows the State Police to scan the lobby in drive-by and recording video surveillance. In general, a comfort station requires approximately 3000 ft² (280 m²) of floor space to accommodate the necessary conveniences to meet the needs of the traveling public. The following provides additional information on the design of comfort stations:

1. Vestibule. The entryway should be a glass enclosure that provides an unobstructed view into the lobby. Use double air-lock doors with high-quality latches and closure hardware to withstand high use.
2. Lobby. The lobby area should provide 800 ft² to 1000 ft² (75 m² to 93 m²) of floor space with a generous amount of windows to maximize natural light. Windows will be provided with safety glass and sectioned in 4 ft (1.2 m) increments or less for ease of repair and maintenance. Protect full-length windows on the inside by placement of handrails and/or bench seating. Locate water fountains away from the windows to prevent splashing. Recessed lighting with vandal-proof flush lenses is desirable. Design emergency lighting to be flush with the ceiling.
3. Vending Area. Locate the vending area to the side of the lobby and provide space for a minimum of six machines. Bench seating is desirable in this area. A security camera should be installed to monitor the vending area. Also, provide a cold-water (softened water) hose bib for the vending machines.
4. Wall Space for Information Boards. All rest area facilities will display a large 4 ft x 6 ft (1.2 m x 1.8 m) State map in a prominent location on either a wall or a center kiosk. Additional wall space of approximately 30 ft² (3 m²) is necessary for information services and notices. Welcome/tourist information centers require additional space for brochures to promote Statewide and local attractions.
5. Telephones. Provide a minimum of one telephone in the comfort station lobby for public use, one of which meets accessibility requirements. TTY telephones (i.e., teletypewriters for the deaf) may be provided in selected facilities in coordination with Central Management Services (CMS). Additionally, one phone is required in the mechanical room and, where a welcome center is provided. One phone is required for the Department of Commerce and Community Affairs (DCCA) attendants. Provide remote ringers in the lobby and outdoors for the mechanical room phone.
6. Vending Storage Room. The vending storage room should be located near the vending area with internal and external access doors. The room should be approximately 225 ft² (21 m²). Provide a 5 lb (2.26 kg) ABC fire extinguisher in the storage room. Also, provide double duplex receptacles and telephone outlet at the proposed location of a desk. Provide hose bibs in the storage area.

7. Rest Rooms. Rest rooms should be a “split” design with open doorways (see Figure 16-1.I). Rest rooms with eight fixtures should be approximately 700 ft² (65 m²). Determine the number of urinals and toilets using Figure 16-1.D. Design the rest room entry to prohibit direct sight lines into rest rooms from the lobby. The split design allows one-half of the rest room to be closed for cleaning, repairs, and off-season low usage. Also, install a diaper changing station in both the men’s and women’s rest rooms. Plumbing and electrical systems should be valved and switched, respectively, to allow repair work in one-half of each rest room. The following provides additional information on rest rooms:
- Standardization of components such as faucets, valves, fixtures, washers, lighting, and locks are essential for ease of replacement. High-quality, heavy-duty vandal proof components are required.
 - Rest room walls should be tiled with a neutral color for ease of maintenance.
 - Construct toilet stall partitions with minimum 4-in (100-mm), glazed-tile concrete blocks.
 - Recessed toilet paper holders are desirable. Consider large volume type multi-roll dispensers (vandal proof).
 - Provide three-quarter length stainless steel stall doors with heavy-duty hinges and latches.
 - Toilet stools will be of high-quality, “institutional type,” floor-mounted, rear-discharge fixtures. Consider using stainless steel or cast iron.
 - Specify use of water-saving, automatic-flushing devices with an override.
 - Install wash basins (i.e., lavatories), other than accessible wash basins, with heavy-duty, twist-type, self-closing faucets with cam ball-bearing pressure plates or automatic controls (ADA compliance).
 - Specify access doors below basins to be manufactured of stainless steel material made to prison standards.
 - Provide an infrared sensory device at accessible wash basins.
 - Include a small plate glass mirror over wash basins. Include a lower facing mirror for ADA compliance.
 - Specify and locate heavy-duty hand dryers near the lavatories to minimize a slippery floor condition.
 - Provide heavy-duty soap dispensers that will not drip onto floor.

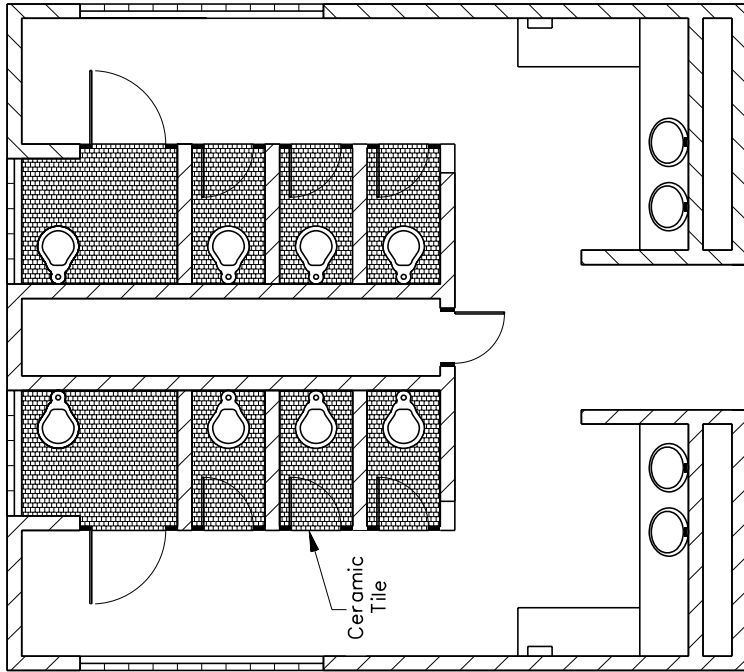

WOMEN'S RESTROOM

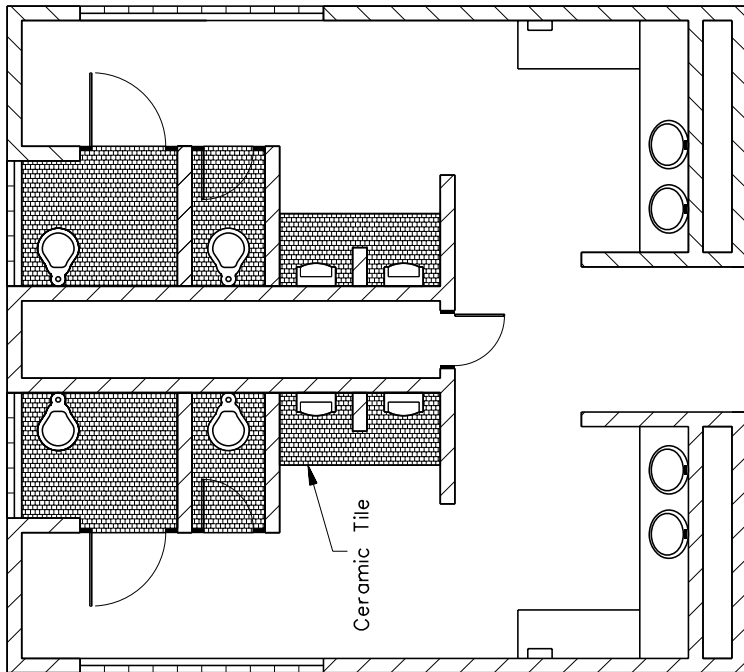

MEN'S RESTROOM

TYPICAL REST ROOM LAYOUT
(Rest Rooms with Stalls for the Disabled)

Figure 16-1.1

8. Lighting. The lighting of a rest area is accomplished by a combination of high-mast lighting and pole lights. Pole lights that are 45 ft (13.5 m) high with 250 watt, high-pressure sodium luminaires are most appropriate to illuminate entrance and exit terminals, as well as ramps leading to and from the parking areas. The high-mast lighting is normally applicable to parking and multi-use areas with poles of 100 ft (30 m) in height. Where practical, provide flagpole lighting with fixtures mounted above ground in inconspicuous locations. Recess all lights on the sides of buildings with screen covers to prevent bird nesting. Prepare lighting plans according to the criteria in Chapter 56. Design all light poles to be of a non-breakaway design; see Section 38-4.11.
9. Flooring. Provide terrazzo flooring in the lobby and rest rooms except for the tile flooring under urinals and stalls. Terrazzo flooring will be curved upward at the edges (i.e., where it meets the wall) to enhance the cleaning process. Consider using uric acid resistant material under urinals.
10. Sidewalks. Place sidewalks adjacent to all curb parking areas and design them to comply with accessibility requirements (ADA). Entrance walks to the comfort station should provide direct access from the parking area and should not be obstructed by signing, bench seating, or planting areas. Accessories (e.g., drinking fountains, signing, newspaper containers, recycling receptacles) should be positioned adjacent to the sidewalk and anchored to concrete pads. Provide a specific location for newspaper dispensers.

Other than the main entrance to the comfort station, sidewalks should be 5 ft (1.5 m) wide and constructed of concrete with a slip-resistant surface. Do not include wood slats at expansion construction joints. Other recreational walkways may be constructed with loose gravel, shredded bark, or similar loose material, to allow extended walks to other natural areas of the facility. Consider ADA compliance requirements. Provide nature trails where site conditions warrant such amenities.
11. Unisex Rest Room. This room serves the disabled person who needs assistance. It should be located off the lobby and is generally 60 ft² (6 m²) in which one toilet and one lavatory are provided with inside locking door.
12. Mechanical/Storage Room. This room will house all of the mechanical equipment necessary to serve the facility. Approximately 350 ft² (32 m²) is required with access doors to both the interior lobby and the exterior. Provide a 5 lb (2.26 kg) ABC fire extinguisher in this room. Also include a desk, telephone, and an area for security system computer and monitors in the room. Storage space is required with shelving for toiletry items, cleaning liquids, appliances, and electronic equipment for the security system.
13. Code Blue Emergency Phones. If these are provided, install a minimum of one wall-mounted phone in the interior of the lobby area, and one post-mounted in the exterior of the building located in the car parking area and truck parking area. Install additional units as deemed necessary.

14. Welcome Centers/Visitors Center. A welcome/visitors center generally requires an additional 300 ft² (28 m²) of flooring for a service counter and storage room. Provide a minimum 8 ft (2.4 m) counter for the distribution of brochures and/or information services. Also provide a gate to secure the counter area and a storage room of approximately 250 ft² (23 m²).

16-1.05(g) Other Amenities

The multi-use area provides a restful environment for the traveler and allows some limited recreational activities. Many facilities offer a scenic vista to the adjacent landscape as well as access to lakes, creeks, and wooded areas. Use the following guidelines to provide the most desirable elements of a rest area facility:

1. Picnic Tables. Use Figure 16-1.C to determine the desired number of picnic tables. Generally, ensure that 33% of the tables are sheltered with an appropriate number being wheelchair accessible. Sheltered tables are not be required where an adequate number of trees would provide some shade for picnic tables. Sidewalks should interconnect approximately 50% of the picnic tables, particularly those tables that are wheelchair accessible.

The design of the shelters should be compatible with the design of the comfort station. Ensure the shelter design takes in consideration to exclude birds and insects from gathering in the rafters. Generally, lighting in the shelters is not required, but certain locations may warrant some illumination. Anchor picnic tables to concrete pads to prevent vandalism. Where appropriate, place tables on parking lot islands or on the backside of truck parking areas.

2. Playground. Provide a children's playground in a convenient location that attracts its use, but does not impede access to the comfort station. Locate the playground area as near to the car parking area as practical, but a sufficient distance away to enhance the safety of playing children. A general size of 30 ft x 40 ft (9 m x 12 m) provides an acceptable area to install a variety of playground equipment.

The area should have a fixed border to retain the surface material. Consider using rubberized surface on top of concrete base for ease of maintenance and longevity of surface. Ensure that the playground meets accessibility requirements (ADA) and includes a sufficient number of play equipment to accommodate the needs of disabled children. The following ASTM Standards can be used as guides for the construction of playgrounds:

- ASTM F1487 – 07ae1 “Standard Consumer Safety Performance Specifications for Playground Equipment for Public Use,” and
- ASTM F1292 – 04 “Standard Specification for Impact Attenuation of Surfacing Materials within the Use Zone of Playground Equipment.”

3. Pet Walk. Provide a mowed pet walk area at all rest area facilities. The location should be a designated area that is well signed and well-lit at night. Also, the area should be away from the parking lot, picnic tables, and playground.

16-1.05(h) Accessibility Requirements

Design all elements of the rest area facility to properly accommodate the physically disabled according to the criteria presented in Chapter 58, *ADA Accessibility Guidelines for Buildings and Facilities*, and the *Illinois Accessibility Code*.

16-1.05(i) Utilities

Generally, rest areas are located in rural areas where utility services are not readily available. Water, electric, gas, and sewer services are necessary for a rest area facility. The following provides information on these rest area utilities:

1. Water. It is highly desirable to obtain water service from an adjacent municipal system. If this option is not available, then use a well-water system. If a well system is used, provide for a secure storage area for water treatment chemicals and softener salt. Also, use a back-up well and water storage (3000 gallon (11,350 L) plus) to maintain adequate supply and pressure during peak periods. Determine water demand from Figure 16-1.D. Evaluate all water systems, well or municipal, for quality and, if deemed necessary, treat to remove objectionable minerals and/or gases. Hard water also should be treated to avoid early deterioration of fixtures.
2. Electricity. Obtain electrical service from the local utility company. Provide a high-efficiency, commercial-grade cooling unit in the facility to cool all areas of the building. Where a feasible, include an emergency generator to operate enough lighting and machinery to function.
3. Gas. Consider natural gas where readily available to provide for the heat source. The use of propane gas is not desirable because of the potential for vandalism. Perform life-cycle cost analyses of energy sources, for heat and cooling requirements. Provide a high-efficiency, commercial-grade heating unit in the facility to heat all areas of the building and locate controlled access thermostats inside the mechanical room.

Consider using geothermal, solar, and/or wind power to augment traditional heating/cooling systems. However, alternative energy systems should be carefully investigated and considered and, where practical and financially feasible, incorporated into the design of the comfort station.

4. Sewer. It is highly desirable to connect sewer systems to a local municipal system. Where this is not practical, consider the construction of sewage lagoons with aeration capability. Consider installation of an inline mechanical grinder to reduce the need to sewer rod a clogged line. Other sewage systems that may be considered include:

- purification mounds (Wisconsin mound),
- recirculating sand-filter systems, and
- self-contained systems of reusable chemicals.

Perform life-cycle cost analyses to determine the appropriate system for the facility. Size sanitary sewer lines and lift stations in accordance with the *Illinois Plumbing Code*. Design lift-station pressure switches for specific requirements and pumping demands. Provide a malfunction or power-outage warning signal in the building for wells and lift stations. Provide for sewer gas escapement. Built-up sewer gases combining with moisture will create sulfuric acid that will greatly reduce the life of untreated metal and concrete components.

16-1.05(j) Outdoor Electrical and Mechanical Equipment

Where practical, locate heating and air conditioning equipment indoors or on the building rooftop. If the only reasonable outdoor location is at ground level, then provide a security fence around the equipment that is architecturally compatible with the building design.

Locate electrical transformers and exterior electrical cabinets on an inconspicuous side of the building away from the view of entering patrons. If necessary, screen these items from view with plantings or architecturally compatible fencing. Coordinate with the utility company for required equipment access clearances.

16-1.05(k) Landscaping

When cost effective, preserve existing shade trees and other natural features to increase the aesthetic value of the site. Develop the facility with minimal disturbance to natural terrain and existing plant growth. Supplement existing vegetation with landscape treatments to achieve an environment conducive to rest and relaxation. Where applicable, give consideration to the acquisition of adjacent right-of-way or easement where a scenic view or natural attraction can be correlated with shorelines, ridgetops, woods, and/or other natural features.

Promote the use of low-maintenance features in a facility's landscape plans. Consider providing earth mounding to screen features such as sewage lagoons and to enhance the visual effect of plantings. See Chapter 59 for additional information on landscaping and plant material.

16-1.06 Rest Stops

16-1.06(a) General

Rest stops are facilities constructed on State highways other than freeways or expressways. These facilities are generally located on one side of the highway and serve both directions of travel. The need for a rest stop is initiated by the district and submitted to the RAC for concurrence. Also included are scenic overlooks and roadside tables. Scenic overlooks also may provide rest room facilities, enlarged parking facilities, and picnic tables. New rest stops or

improvements to an existing rest stop may be considered a Type I project for noise and consequently require a noise analysis. Traffic noise analyses shall be conducted in accordance with Section 26-6 "Noise Analyses" of this BDE Manual. The *IDOT Highway Traffic Noise Assessment Manual* has been prepared to provide guidance on how to implement the policy for IDOT projects or projects being reviewed by IDOT. The guidance manual provides information to be included in the environmental documentation.

16-1.06(b) Site Selection

When it is determined that a State highway should be considered for rest stops, representatives of the RAC and the district will investigate and prioritize potential sites. Most of the site selection guidelines presented in 16-1.04(b) are also applicable to rest stops. Locate rest stops at sites with natural settings and shade. To avoid its misuse as a local park, do not locate rest stops close to urban areas.

Rest stops usually have rest rooms, limited parking spaces, and several picnic tables. Generally, running water and flush toilets are provided unless the availability of water is not practical for a particular site, in which case a vault type is used. A minimum designed facility requires approximately 4 acres (1.6 ha).

16-1.06(c) Design Guides

A typical rest stop configuration is illustrated in Figure 16-1.J. Entrances to the facility and the inner roadway should accommodate the movement of two-way traffic. Provide minimum intersection sight distance as discussed in Section 36-6. Entrance radii are typically simple curves, and the roadway surface beyond the limits of the shoulder should be an aggregate material.

Base the estimated vehicle parking spaces on 20-year, two-way ADT. Provide for one passenger car stall for every 500 vehicles passing the facility and one truck stall for every four passenger car stalls. A minimum number of four car stalls and one truck stall is necessary to warrant the consideration of such a facility. Parking stalls, although not striped, should be provided for passenger cars at 10 ft x 20 ft (3 m x 6 m) and for trucks at 12 ft x 60 ft (3.6 m x 18 m). Use a WB-55 (WB-17) design vehicle for turning roadway criteria, see Chapter 36.

16-1.06(d) Access Control/Right-of-Way

A rest stop facility shall be provided with access control to enhance the site and to preclude the future development of adjacent commercial properties. This will prevent the rest stop from being used as customer parking. Figure 16-1.J also illustrates the extent of access control that should be acquired to ensure the intended functions of the facility. Exercise engineering judgment in acquiring access rights because more or less distance may be required depending upon the exact locations of property lines.

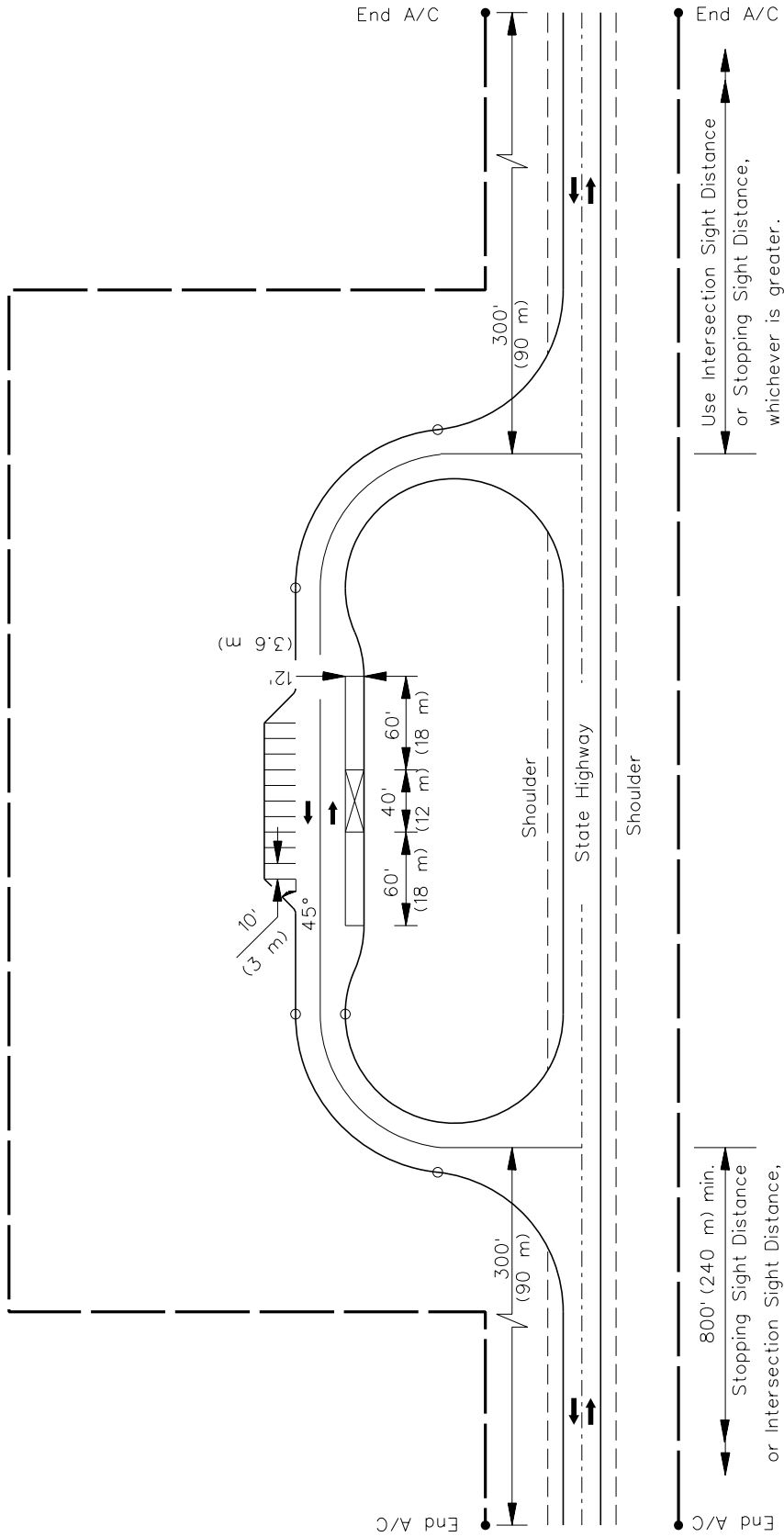

Note: Design all radii and roadway widths consistent with Designated State Truck Route System classification.

TYPICAL REST STOP

Figure 16-1.J

16-2 WEIGH STATIONS

16-2.01 General

Truck weighing facilities are necessary to:

- collect data for pavement research,
- monitor single axle loads (ESAL's),
- inspect trucks for safety violations, and
- remove illegal trucks from the Illinois highway system.

Other agencies (e.g., State Police, Department of Agriculture, Interstate Commerce Commission) also use weigh stations for inspection purposes. A weigh station provides a means to monitor vehicles for compliance with Federal Regulations and State statutes. Interstate weigh stations are discussed in Section 16-2.03. Arterial weigh station facilities are discussed in Section 16-2.05.

16-2.02 Weigh Station Committee

To ensure a level of consistency in all matters concerning weigh stations, the Department has established a Weigh Station Committee. The Committee directs and monitors the truck weight program. It also provides coordination with the districts, the Illinois State Police, and the Department of Agriculture. In addition to serving as a technical liaison with these agencies, the Committee is responsible for providing long-range planning and developing policies for design, construction, operation, and maintenance. The Weight Enforcement Engineer of the Bureau of Operations chairs the Committee. The Committee is comprised of representatives from IDOT bureaus and other agencies as follows:

1. Division of Highways. The Division of Highways is responsible as follows:
 - a. Bureau of Operations. This bureau is charged with maintaining the weigh station facilities, maintenance of the electronic scales, signing, and traffic operations.
 - b. Bureau of Design and Environment. This bureau is responsible for providing the environmental survey of the site and also lets all construction contracts except those concerning the scale house. New weigh stations or improvements to an existing weigh station may be considered a Type I project for noise and consequently require a noise analysis. Traffic noise analyses shall be conducted in accordance with Section 26-6 "Noise Analyses" of this BDE Manual. The *IDOT Highway Traffic Noise Assessment Manual* has been prepared to provide guidance on how to implement the policy for IDOT projects or projects being reviewed by IDOT. The guidance manual provides information to be included in the environmental documentation.

- c. Bureau of Bridges and Structures. This bureau prepares the scale pit and inspection pit design.
2. Capital Development Board. This agency is responsible for the preparation of construction drawings and contract specifications for the scale house and appurtenances. It will also let the contract for the construction of the scale house and provide construction supervision.
3. Office of Planning and Programming. This office is responsible for collecting and analyzing data concerning truck weights and dimensions.
4. Illinois State Police. This agency is responsible for the enforcement of State statutes regarding weight and dimension limitations.
5. District. The district is responsible for the geometric design of the weigh station layout and for preparing the detailed plans for roadway construction of the weigh station. The district will also provide survey data, as needed by the Capital Development Board, for the design of the scale house.

16-2.03 Interstate Weigh Stations

16-2.03(a) Site Selection Criteria

Weigh stations on the Interstate system generally should be located near State lines to serve inbound traffic. Other sites within the State should be considered on high truck volume routes. Site selection for weigh station facilities should attempt to restrict by-pass opportunities via convenient alternate routes. The Weigh Station Committee will determine the need to construct a facility within a specific corridor. Representatives of the Weigh Station Committee and the district will select the site and submit the proposal to the Committee for concurrence. Consider the following criteria when selecting a site for a weigh station:

1. Utilities. Ensure that utilities are available to adequately serve the scale house.
2. Spacing. Provide a distance of approximately 4000 ft (1200 m) between the weigh station entrance or exit ramp gore and any adjacent interchange ramp gore.
3. Sight Distance. Provide decision sight distance to the weigh station exit ramp gore.

16-2.03(b) Planning

The following procedures are established to provide the proper coordination of various agencies involved in the planning of weigh stations:

1. Determine Location. Representatives of the district and the Weigh Station Committee will determine a suitable location.

2. Preliminary Layout. Prepare and submit a preliminary layout in the form of an aerial mosaic or scale drawing showing the following information:
 - the scale house location and limits of entrance and exit terminals;
 - the distance from the exit or entrance ramp gore to the ramp gore of the nearest interchange or to the nearest intersection, and
 - the availability of telephone, electrical power, heating fuel, water, and sewer services.
3. Field Inspection. Conduct a field inspection of the site and ensure that all agencies involved are invited to attend.
4. Road Plan Preparation. Upon approval of the site by the Weigh Station Committee, prepare the road plans and submit them to the BDE. Appropriate low-maintenance landscaping should be included in the roadway plans or as a separate contract.
5. Preparation of Lighting Plans. All weigh stations should be illuminated. See Chapter 56 for the data to be submitted for preparing lighting plans.
6. Scale Pit Design. The district shall submit the following data for the scale pit design:
 - soil borings and blow counts at each end and in the center of the proposed scale pit to determine the size and type of footings and whether pilings are necessary,
 - location and details of the pit drainage, and
 - estimated quantities for the pavement and the median section adjacent to the scale and for the approach pavement.

Upon receipt of the above information and a set of roadway plans, the Bureau of Bridges and Structures will prepare the scale pit plans.

Figure 16-2.A provides the required information for the design of weigh stations.

16-2.04 Interstate Design Criteria

16-2.04(a) General

A typical Interstate weigh station facility with weigh-in-motion (WIM) capabilities is illustrated in Figure 16-2.B. A WIM facility virtually eliminates the delay legal trucks experience from stopping at weigh stations. When a truck enters a facility, the dynamic scale in the ramp pavement will sort the vehicle into one of two lanes. The by-pass lane allows a legal weight vehicle to return to the freeway without any further delay. The static scale lane directs the vehicle to the static scales for a more precise weighing. The static lane vehicles then are either returned to the freeway or directed to the detention parking area.

There are five basic operational elements of a WIM facility as follows:

- the deceleration distance,
- the signal zone,
- the storage requirements,
- the acceleration distance, and
- the detention parking area.

1.	Property: (a) Location and orientation of the site and legal description (b) Property lines and dimensions (c) Elevations and/or contours, including at least one bench mark (d) Layout of proposed approach, weighing platform and scale house and exit.
2.	Test Soil Borings (a) To be made in area of proposed new buildings when required (b) Type of soil and bearing capacity in pounds per square foot (kN/m ²)
3.	Availability of water supply: (a) City water supply available Location Distance from site Size of main Water pressure Easements required (b) Well to be provided Information on wells in vicinity Depth Size Yield in cubic feet per second (m ³ /s) Location Water characteristics Test holes drilled
4.	Availability of sewers (a) Sanitary district or city sewers Location Distance from site Size at proposed connection Invert elevation Easements required (b) Septic tank required Absorption tests
5.	Availability of natural gas for heating (Input 55 ft ³ (1.6 m ³) per hour per building): (a) Natural gas available Name of utility company Location of service connection Distance from site Specific gravity pressure Size of main at connection Easement required
6.	Availability of electrical service (17 kW per building, ramp lighting additional) Name of utility company Service available Volts Phase Location of service Distance from site Telephone Service: Name of company

Location of service
Distance from site

DATA AND SURVEY INFORMATION FOR PROPOSED INTERSTATE WEIGH STATION

Figure 16-2.A

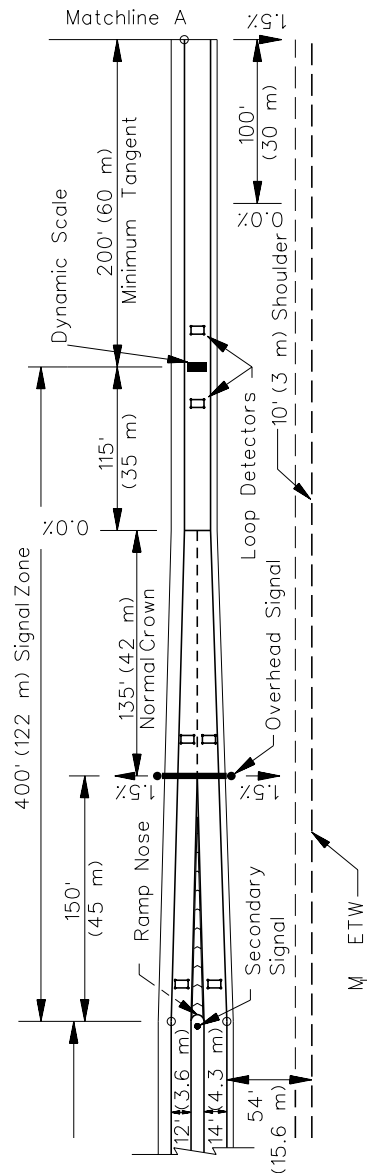
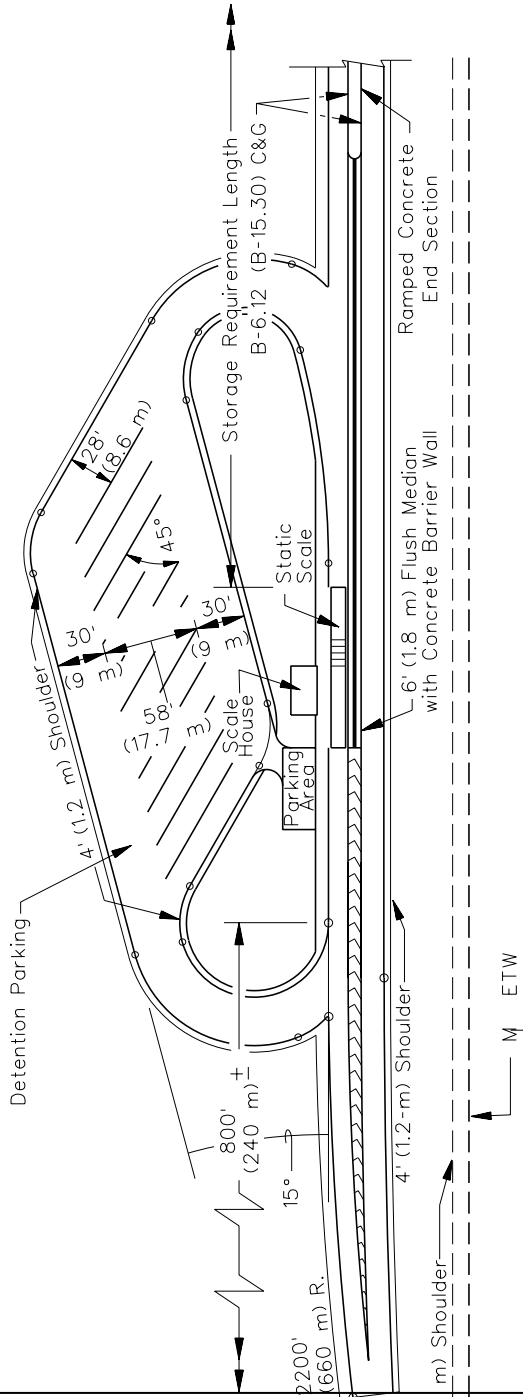

TYPICAL INTERSTATE WEIGH STATION WITH WEIGH-IN-MOTION

Figure 16-2.B

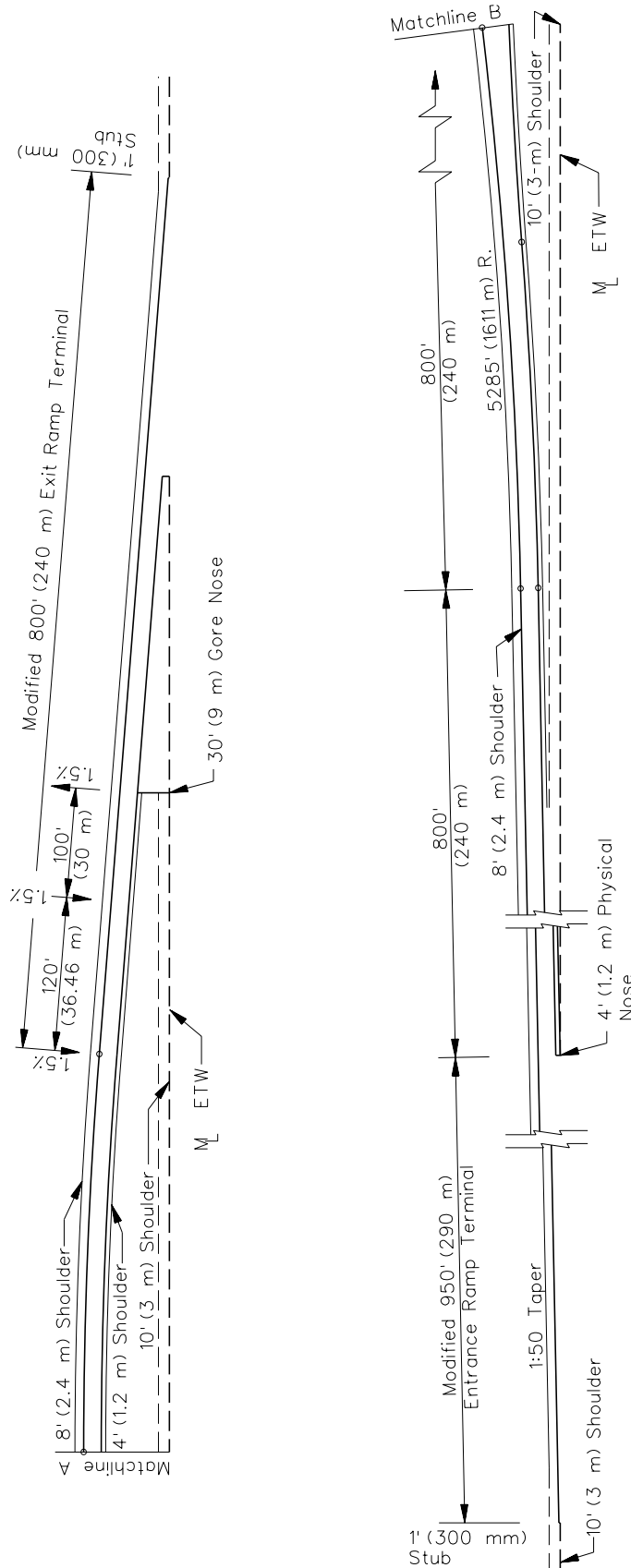

TYPICAL INTERSTATE WEIGH STATION WITH WEIGH-IN-MOTION

Figure 16-2.B
(Continued)

Design the weigh station to accommodate the operational characteristics of a WB-65 (WB-20) design vehicle. Provide advanced signing in accordance with the *ILMUTCD*. Coordinate signing with the Bureau of Operations.

16-2.04(b) Weigh-in-Motion

The dynamic scale is placed in the exit ramp at the end of the required deceleration length. The WIM electronic processor can determine:

- vehicular speed,
- length of wheelbase,
- gross weight,
- axle weight,
- axle spacing,
- vehicle length, and
- classification of 13 different vehicle types.

A vehicle that is within 3% of its maximum legal weight limit or exceeds its legal limit will be directed to the static scale for a precise weighing. Vehicles that are determined to be within the legal weight limit are directed to a bypass lane and returned to the freeway. As a vehicle passes over the dynamic scale, the vehicle will be directed to the static scale if the driver:

- exceeds the posted speed limit,
- does not maintain a 100 ft (30 m) distance from the rear of the forward vehicle, or
- fails to properly align the vehicle on the dynamic scale.

Pneumatic tubes or electronic sensors are placed on the outer edges of the dynamic scale to detect off-scale occurrences and to override the system to direct the vehicle into the static scale lane.

The “signal zone” is illustrated in Figure 16-2.C which describes critical lengths of the WIM system. Trucks exit the freeway and decelerate to the posted speed of 30 mph (50 km/h) before passing over the dynamic scale. A WIM facility may be designed for a higher speed; however, extend the signal zone accordingly to provide approximately six seconds of signal viewing time.

16-2.04(c) Storage Requirements

At a facility where only a static scale is provided, all trucks will stop and be weighed. Delays at such facilities are frequent and queuing often occurs on the deceleration ramp. Research has determined that approximately 12% of the trucks that enter a weigh facility are near their legal limit and require a more precise weighing on a static scale. Storage length requirements for static scale and WIM facilities are illustrated in Figure 16-2.D. It is imperative that the signal zone of a WIM facility is free of stored vehicles. Consequently, use a safety factor of two in the

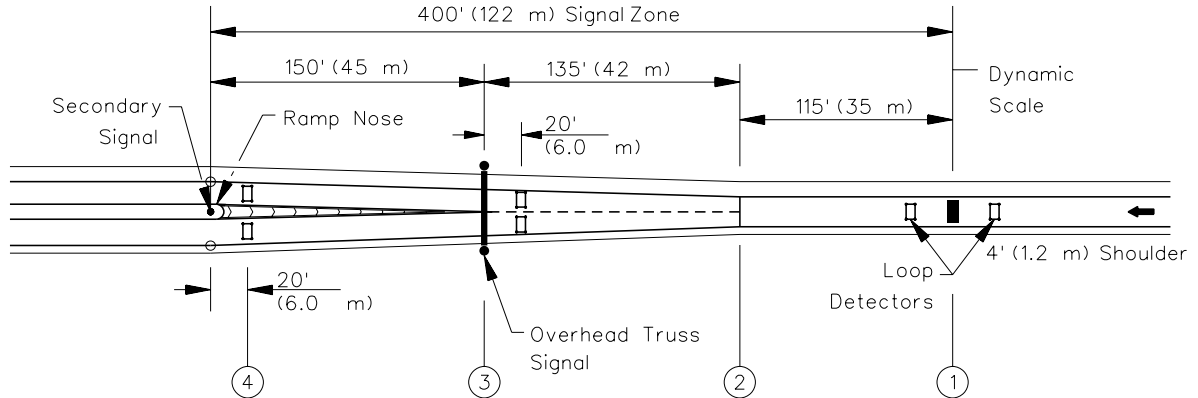

- ① Vehicle approaches the dynamic scale at a posted speed of 30 mph (50 km/h). Loop detectors adjacent to the dynamic scale will determine vehicular speed.
- ② The distance of 115 ft (35 m) past the dynamic scale is based on the length of a large truck (i.e., 75 ft (22.5 m)) plus one second travel time at 30 mph (50 km/h) (i.e., 40 ft (13 m)). At this position, an overhead signal arrow will direct the driver to the proper lane. The remaining distance to the overhead signal is 135 ft (42 m) which allows nearly three seconds of viewing time. Loop detectors located in front of the overhead signal truss will deactivate the overhead signal and simultaneously activate the secondary signal allowing a continued lane arrow assignment.
- ③ The overhead signal truss displays a lane arrow for proper lane assignment. The truss signal is deactivated when the vehicle passes over the loop detector preceding the truss. The secondary signal is simultaneously activated as a vehicle passes over the loop detector. This provides a continuation of the lane arrow assignment for an additional three seconds.
- ④ When a vehicle passes over the loop detector preceding the secondary signal, it deactivates the secondary signal and detects a vehicle that violates the proper lane assignment. When a violation occurs, a warning alarm is activated in the scale house and the violator is intercepted and directed to the detection parking area.

WEIGH-IN-MOTION (WIM) SIGNAL ZONE

Figure 16-2.C

Design Year Two-Way ADT _____

One-Way ADT x 60% _____

x % Commercial Vehicles _____ = _____

% Multiple Units (MU) _____ = _____ MU

% Single Units (SU) _____ = _____ SU

MUPH x 0.06 = _____ MUPH

SUPH x 0.09 = _____ SUPH

$\frac{MUPH \times 75}{8.2}$ = _____ MU Storage Length (ft) US Customary

$\frac{MUPH \times 22.5}{8.2}$ = _____ MU Storage Length (m) Metric

$\frac{SUPH \times 30}{8.2}$ = _____ SU Storage Length (ft) US Customary

$\frac{SUPH \times 9.0}{8.2}$ = _____ SU Storage Length (m) Metric

Add SU + MU Storage = _____ Static Scale Required Storage Length (ft) (m)

Weigh-in-Motion (WIM) Storage Calculations:

Total Required Storage Length (Static Scale) _____ x 25% = _____ WIM Required Storage Length ft (m)

REQUIRED STORAGE LENGTHS

Figure 16-2.D

storage equation that increases the 12% trucks-entering value to 25%. Provide the calculated storage length between the secondary signal and the static scale. Generally, a concrete barrier wall is desired in the median adjacent to the storage lane with a length equal in distance to the storage length requirements.

16-2.04(d) Entrance and Exit Terminals

The exit and entrance terminal designs are modified versions of the typical designs. The exit ramp terminal design provides a 4°30' divergence angle from the freeway which normally will allow the design of a single horizontal curve to be used in advance of the dynamic scale. Provide a minimum distance of 800 ft (240 m) from the ramp gore to the dynamic scale to accommodate vehicular deceleration, allows drivers to maintain a steady speed, and achieve proper vehicular spacing. The approach tangent preceding the dynamic scale should desirably be level and smooth for 200 ft (60 m) to enhance scale performance. The ramp downstream from the dynamic scale also should be level for 100 ft (30 m).

Provide an acceleration distance of approximately 2000 ft (600 m) from the static scale to the gore nose of the freeway for trucks to achieve an acceptable speed before entering the freeway. Adjust the acceleration distance where the ramp terminal is on a grade greater than 3% or where the freeway level of service is adversely affected by the truck's merging speed. See Section 37-6.02 for additional guidance.

16-2.04(e) Detention Parking Requirements

Design the detention parking area to accommodate a minimum of 10 trucks that may be held for overweight violations or vehicle inspections. The turning roadways to and from the parking area should have a 50 ft (15 m) inside radius and are generally 30 ft (9 m) wide. Adjust the parking angle for specific site conditions. Provide a 4 ft (1.2 m) concrete shoulder on the turning roadways and parking area. See Figure 16-2.B.

16-2.04(f) Pavement Design

Design the weigh station ramps and detention parking area according to Section 54-1.08. Truck weighing stations are considered "high stress" locations. See Chapter 54 for pavement and shoulder design guides.

16-2.04(g) Vehicle Inspection Pit

A vehicle inspection pit may be provided to enhance the safety inspection of trucks or other special vehicles. Locate the pit adjacent to the detention parking area to provide joint parking opportunities. A schematic design is shown in Figure 16-2.E.

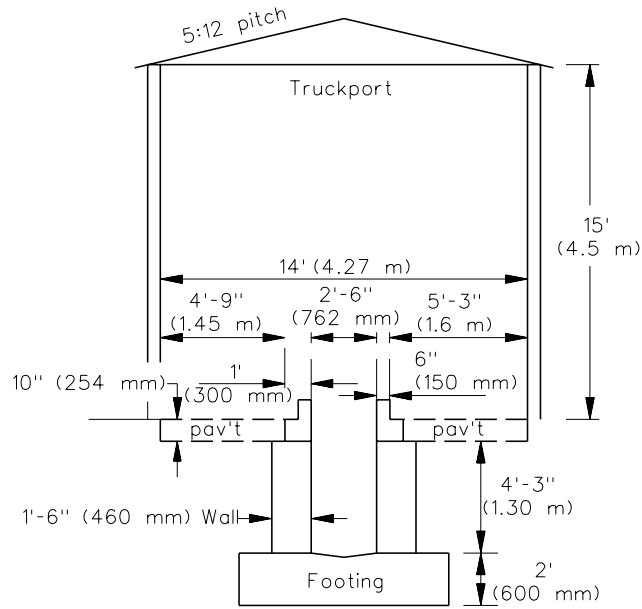

TYPICAL CROSS SECTION OF INSPECTION PIT

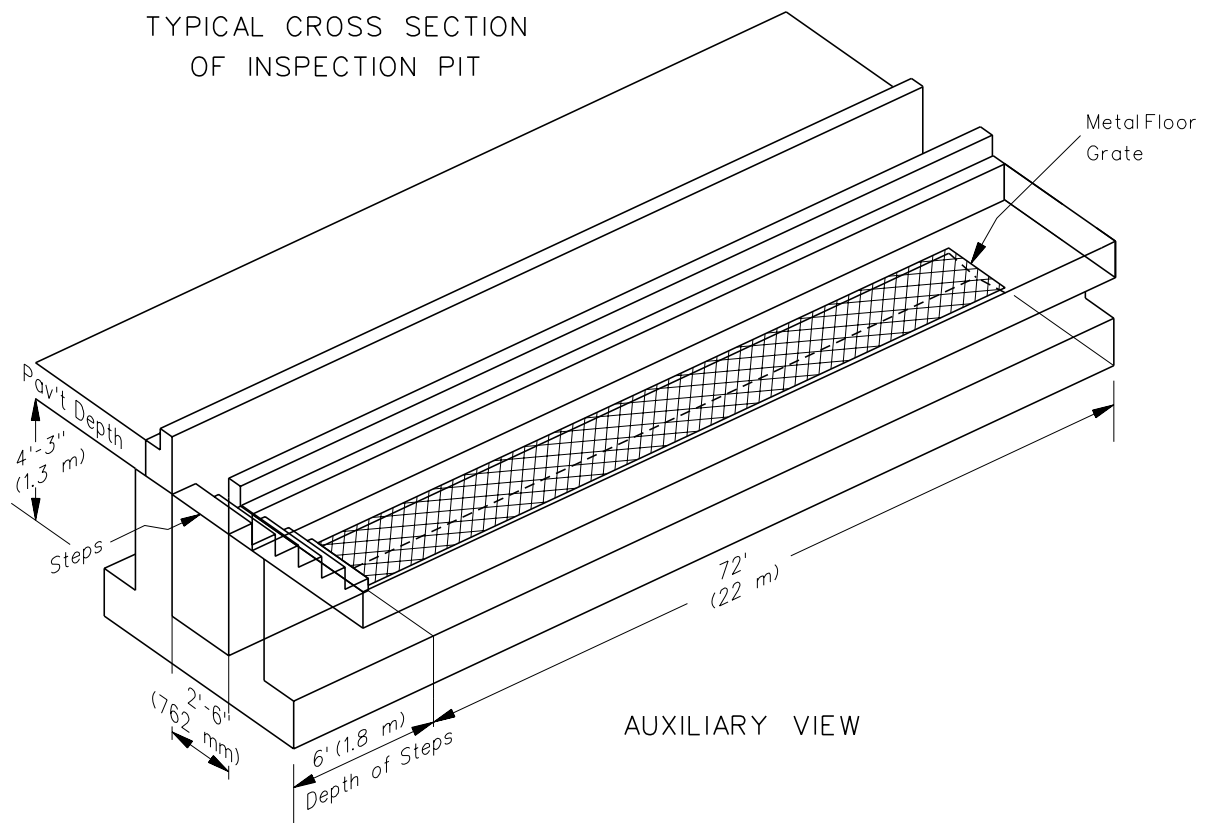

TYPICAL INSPECTION PIT DESIGN

Figure 16-2.E

16-2.04(h) Conversion of Static Scale Facility to Weigh-in-Motion

Most existing static scale weigh stations can be converted to weigh-in-motion facilities within the existing right-of-way limits. Reconstruction will be required of the exit ramp terminal, ramp proper, and detention parking area. The remaining elements of the weigh station (i.e., scale house, static scale, by-pass lane, storage lane, and acceleration ramp) only will need replacement if in deteriorated condition.

Design the exit ramp terminal as illustrated in Figure 16-2.B. With the conversion of existing facilities, the ramp should be aligned with the existing by-pass lane. Extend the existing 6 ft (1.8 m) median upstream a distance equivalent to the required storage length. Typically, a concrete barrier wall should be constructed between the by-pass and static lanes.

Widen the turning roadways to and from the detention parking area to accommodate the WB-65 (WB-20) design vehicle criteria. Design the detention parking area in a diagonal pattern according to Figure 16-2.B. The existing scale house should adequately accommodate the new WIM equipment without expansion.

16-2.04(i) Intelligent Transportation Systems (ITS)

Weigh station facilities may be provided with electronic systems that can monitor passing trucks equipped with transponders. A dynamic scale is located in the mainline pavement preceding the exit ramp to the weigh station. A roadside reader connected to the scale house computer system emits a signal to an approaching truck that is equipped with a transponder. The roadside reader relays the signal to the scale house computer, identifying the particular vehicle, while the dynamic scale computer analyzes the vehicle's weight. A record is created by merging the weight of the vehicle with the transponder information. Using the merged record, a signal is transmitted back to the transponder. A green light indicates approval to by-pass the weigh station and a red light indicates that the vehicle must exit into the weigh station for the normal weighing process.

These electronic systems can be expanded to include additional features (e.g., tracking hazardous materials, identifying mechanical malfunctions) and may be interconnected to other State systems.

16-2.05 Arterial Weigh Stations**16-2.05(a) General**

Arterial weigh stations are constructed on State highways other than freeways. This facility is typically located on one side of the highway and serves both directions of travel. The Weigh Station Committee determines the need for an arterial weigh station. A 12 ft (3.6 m) wide static scale is provided for single and dual-axle weighing.

16-2.05(b) Site Selection

Arterial weigh stations generally are located at ports-of-entry on high-volume arterial State routes. Other intra-State facilities may be located at high-volume truck routes as deemed necessary.

Where it is determined that a specific corridor of a State highway should be considered for an arterial scale facility, representatives of the district and the Weigh Station Committee will investigate feasible locations and determine a suitable site. Criteria for site selection primarily are based on availability of right-of-way, minimizing by-pass opportunities, and availability of utilities to support the scale house.

16-2.05(c) Design Guides

The geometric design of an arterial weigh station is illustrated in Figure 16-2.F and should accommodate the appropriate design vehicle for the highway classification. A facility is designed to store two or four vehicles from both directions of travel. If additional storage is required, construct auxiliary lanes on the mainline. For example, if opposing volumes restricts left-turn entry, consider providing a flush left-turn lane on the State highway.

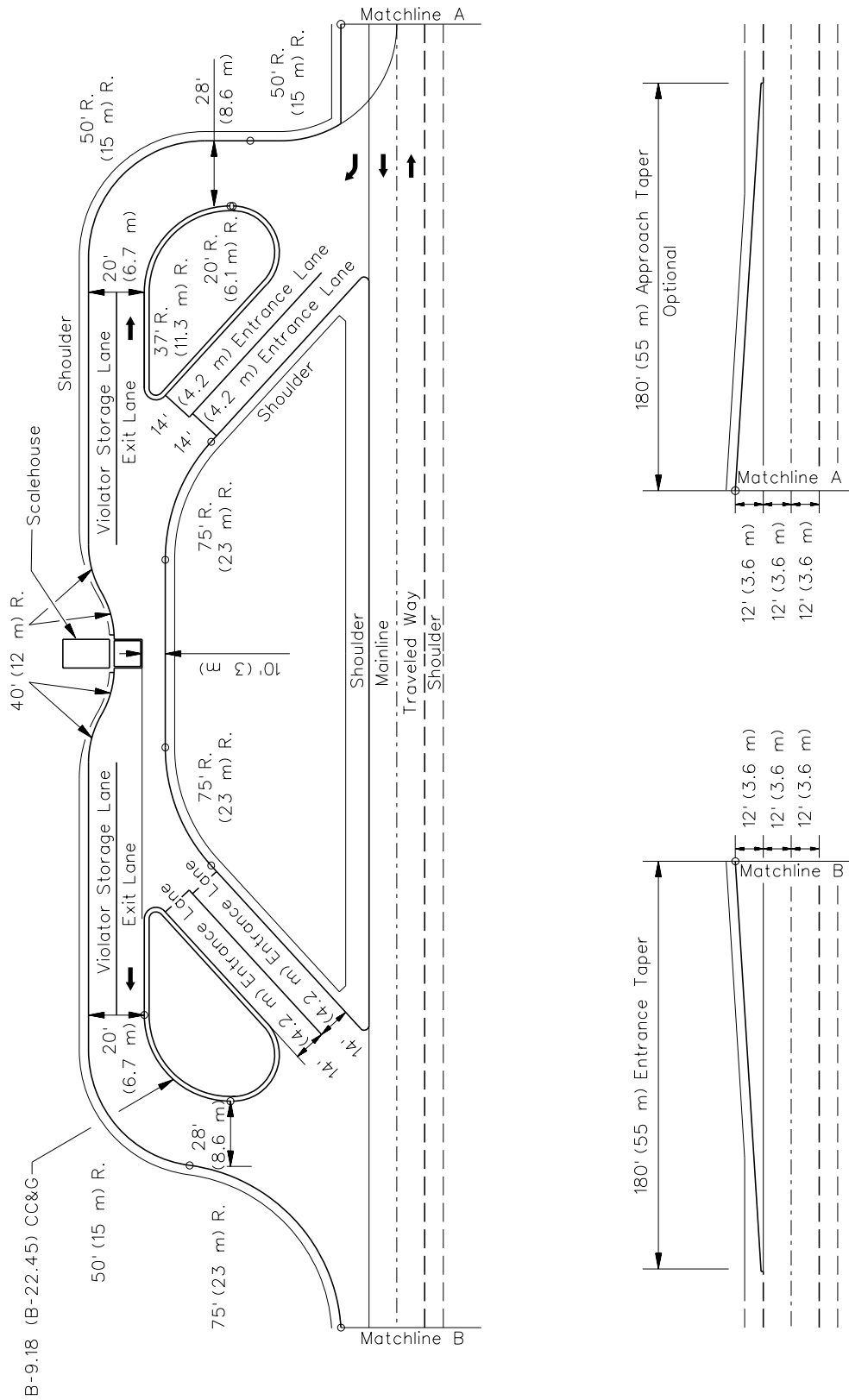

TYPICAL ARTERIAL WEIGH STATION

Figure 16-2.F

16-3 CONTRACT PLANNING AND COORDINATION

16-3.01 General

All rest area type facilities and weigh stations are inherently complex to build because they can involve as many as seven separate construction contracts to complete each project. Therefore, it is important to clearly define the scope of each contract relative to the others. Doing this can prevent overlapping scopes of work or omitting necessary work tasks. Both situations ultimately lead to expensive contractual problems in the field.

16-3.02 Scope

All rest area type facilities and weigh stations generally will be built through a combination of contracts. The following presents the recommended sequence of contract award:

1. Grading and Paving. Grading and paving, a unit-price contract, will be awarded first.
2. Lighting. The second award will be for lighting, a unit-price contract.
3. General. The general work typically is awarded as four lump-sum contracts as follows:
 - general,
 - plumbing,
 - HVAC, and
 - electrical.

The general contractor is named as the prime contractor who coordinates the work of the other three assigned contractors.

4. Landscaping. The landscaping award, a unit-price contract, typically is the last contract to be awarded.

16-3.02(a) Division of Work

It is relatively simple to determine the scope of work for each contract. However, certain aspects of the work in each contract clearly affect subsequent contracts. Consider the following design elements to better avoid conflicts and omissions of scope:

1. Grading and Paving Contracts. Grading and paving contracts include the following items:
 - earthwork,
 - pavement and shoulders,
 - curbs,
 - storm sewers,
 - right-of-way fencing,

- roadway signing,
 - pavement striping, and
 - seeding.
2. Lighting Contracts. Lighting contracts generally include the following items:
- light poles,
 - light towers,
 - sign lighting,
 - unit duct and wiring, and
 - controller.
3. General and Assigned Contracts. General and assigned contracts include the following items:
- complete buildings,
 - utility connections,
 - water system,
 - sanitary sewer system,
 - site furnishings, and
 - sidewalks.
4. Landscaping Contracts. Include the following items for landscaping contracts:
- sodding and final seeding,
 - trees and bushes, and
 - flower plantings.
5. Security/Surveillance/Code Blue. For security and surveillance concerns, consider the following:
- site placement and installation of equipment,
 - maintenance, and
 - training.

16-3.02(b) Coordination of Scope

Experience has shown that the following suggestions simplify the construction process and ultimately reduce costs:

1. Grading and Paving Contracts. Consider the following for grading and paving contracts:
- a. Topsoil. Rather than placing topsoil where buildings and sidewalks will be located, stockpile the topsoil for placement after all other general contract work is complete. This will promote better turf growth.

- b. Temporary Seeding. Specify temporary seeding for areas that will be disturbed under future contracts.
 - c. Curb Slipforming. Prohibit slipforming of PCC curbs where they will abut PCC sidewalks. Formed PCC curbs will provide a better appearance adjacent to sidewalks.
 - d. Earthwork. Design earthwork grades in sidewalk areas to ensure compliance with accessibility requirements. Design earthwork carefully to minimize excavation during the general contract.
2. Lighting Contracts. Consider the following when preparing lighting contracts:
- a. Unit Ducts. Coordinate unit duct routing with building utilities to avoid conflicts.
 - b. Lighting Controller. Allow space in the mechanical room for the lighting controller.
3. General and Assigned Contracts. Consider the following for general and assigned contracts:
- a. Plan Limits. Establish plan limits of areas to be seeded under the landscaping contract. Beyond these limits, require restoration by the general contractor.
 - b. Topsoil Spreading. After sidewalk and building work is complete, specify the spreading of topsoil that was stockpiled during the grading and paving contract.
 - c. Topsoil Grading. Specify that topsoil remain in a rough-graded condition for the landscaping contract.
4. Landscaping Contracts. The following should be considered when preparing landscape contracts:
- a. Grading and Seeding. Specify fine grading and seeding of all areas that remained in a rough-graded condition under the general contract.
 - b. Number of Contractors. Experience has shown that only one contractor should be responsible for all landscaping work within a clearly defined area. Otherwise, unneeded conflicts will arise.

16-4 REFERENCES

1. NCHRP 324, *Evaluation of Safety Roadside Rest Areas*, Transportation Research Board, 1989.
2. *Traffic Characteristics on Illinois Highways — Bi-Annual Report OPP*.
3. *A Policy on Geometric Design of Highways and Streets*, AASHTO, 2004.
4. *Accessibility Guidelines for Buildings and Facilities*, US Architectural and Transportation Barriers Compliance Board, 1991.

